

>B< Press

>B< Press XL



>B< Press & >B< Press XL
Technical Brochure

½" to 4"

Contents

1 General

1.1	General	1
1.1.1	Quality and certifications	
1.1.2	Features and benefits	
1.1.3	Materials and threads	
1.1.4	Storage and handling	
1.1.5	Black EPDM sealing elements	
1.1.6	Unpressed joint indicator and system testing	
1.2	Areas of Service	2
1.3	Limited Warranty	3
1.4	Product Suitability	3
1.4.1	Drinking water installation	
1.5	System Commissioning	3

2 >B< Press ½" to 2" copper

2.1	>B< Press Copper Fittings – ½" to 2"	5
2.2	Fitting Construction	5
2.2.1	Fitting construction ½" to 2"	
2.3	Product Suitability	5
2.3.1	Compressed air systems	
2.4	Compatible Press Tools	5
2.4.1	Press jaws	
2.4.2	Maintenance ½" to 2"	
2.4.3	Compatible press tools	
2.4.4	Use of tools	
2.5	Installation Requirements	7
2.5.1	Space required for the pressing process	
2.5.2	Insertion depth and minimum distances between pressings	
2.5.3	Minimum distance for press fittings from an existing brazed joint	
2.5.4	Minimum brazing distance to an existing pressed fitting	
2.5.5	>B< Press tube compatibility table	
2.6	>B< Press Installation Process	9
2.7	Product Range	10

3 >B< Press XL 2 ½" to 4" copper

3.1	>B< Press XL Copper Fittings – 2 ½" to 4"	18
3.1.1	Product features	
3.1.2	Stainless steel grip ring	
3.1.3	Seal design	
3.2	Compatible Press Tools	19
3.2.1	Tool chart	
3.3	Installation Requirements	19
3.3.1	Space required for the pressing process	
3.3.2	Insertion depth and minimum distances between pressings	
3.3.3	Minimum distance for press fittings from an existing brazed joint	
3.3.4	Minimum brazing distance to an existing pressed fitting	
3.3.5	>B< Press XL tube compatibility table	
3.4	>B< Press XL Installation Process	22
3.5	Product Range	23

1.1 General

>B< Press fittings are quick and easy to install and are available in copper and lead-free brass. This flame-free range is designed with an innovative 3-point press system, with >B< Press XL (2 ½" to 4") featuring a stainless steel grip ring. Both ranges ensure a secure, permanent leak-free joint that is suitable for multiple applications.

1.1.1 Quality and certification

Conex Bänninger has 110 years of experience in manufacturing innovative products and operates an accredited Quality Management System to EN and ISO 14001.

>B< Press copper and lead-free brass fittings are tested and certified by independent national certification bodies confirming its suitability and reliability for use with potable water applications. >B< Press is certified by the following bodies:

Listings and Certificates	
IAPMO	Z 1117
NSF/ANSI	61
NSF/ANSI	372
ICC-ES	LC 1002

Standards and Codes Compliance	
ASME	B16.51 Copper and Copper Alloy Press-Connect Pressure Fittings
	B31 Code for Pressure Pipe; Standards B31.1, B31.3 and B31.9
	B1.20.1 Pipe Threads, General purpose, Inch
IAPMO	Uniform Plumbing Code (UPC)
	National Plumbing Code of Canada (NPC)
	California Health and Safety Code - Lead Free Plumbing Products
ICC	International Residential Code (IRC)
	International Plumbing Code (IPC)
	International Mechanical Code (IMC)

Other >B< Press International Certifications	
Australia	Watermark
France	ACS
	CSTB
Germany	DVGW
	DNV
Netherlands	KIWA
Marine	Lloyd's register
Poland	ITB
Sweden	KIWA SE
Switzerland	SVGW
UK	WRAS
	BSI Kitemark

1.1.2 Features and benefits

The following are benefits of the >B< Press fitting:

- Suitable for potable water, hydronic heating, chilled water, compressed air, non-medical gases, low pressure steam, vacuum.
- Quick and easy to install, saving on labor costs.
- Permanent, flame-free connection - no hot works permit required.
- Suitable for use with hard, half-hard and soft copper tubes to ASTM B88.
- Unpressed joint indicator assists identification of unpressed joints.
- Manufactured using high quality materials to applicable standards.
- Tested and approved by national and international standard authorities.
- Maximum working pressure 300 psi (for water applications).
- Fifty year limited warranty, for full terms and conditions please see section 1.3.
- Maximum working temperature 250°F.
- 3-point press safety feature for added security. (½" to 2" only).
- >B< Press XL has a stainless grip ring for additional strength.
- No soldering or brazing consumables required.
- Comprehensive range of fittings - sizes from ½" to 4".
- Compatible with commonly available press tools (see section 2.4.3 for >B< Press and section 3.2.1 for >B< Press XL).
- Suitable for concealed water installations.

1.1.3 Materials and threads

>B< Press and >B< Press XL copper fittings are made of oxygen-free copper CU-DHP (material number ASTM C12200) which can be combined with copper tubes in accordance with ASTM B88.

All >B< Press and >B< Press XL threaded fittings are designed and manufactured in accordance with ANSI/ASME B1.20.1 (NPT) and are accordingly 'thread sealed' (threaded connections are conical).

Lead free materials: All >B< Press products comply with the regulations of both NSF/ANSI standard 372 (0.25% or less percent maximum weighted average lead content) and NSF/ANSI 61.

>B< Press >B< Press XL

1.1.4 Storage and handling

Store in a cool and dry place to protect the fittings from contamination, damage and dirt. Keep out of direct sunlight. Fittings should be left in their packaging to preserve the lubrication on the O-rings prior to installation.

1.1.5 Black EPDM sealing elements

>B< Press and >B< Press XL copper EPDM O-ring contains a peroxide cured rubber seal with high elasticity, and excellent cold and heat performance.

Please refer to section 1.2 for the fitting operating parameters for the different applications.

1.1.6 Unpressed joint indicator and system testing

>B< Press benefits from a patented O-ring technology (sizes ½" to 2"). This tri-lobal O-ring allows water to pass through and create a noticeable leak when the system is tested at low pressure (1.5 to 85 psi).

The >B< Press XL (2 ½" to 4") features a larger internal fitting diameter so water can pass through and create a leak path when the system is tested at low pressure (1.5 to 85 psi).

Low pressure testing for leaks or unpressed joints should be done once the installation has been completed. The benefit from this technology is that it will identify any unpressed joints within the system, allowing the installer to revisit and press any joint that may have been unpressed. The unpressed fittings can then be pressed without having to drain the system, saving time.

1.2 Areas of Service

>B< Press copper fittings are suitable for use in the following applications.

Type of service	Comments	Pressure psi	Temp °F
Fluids/water			
Hot and cold potable water	-	300	32 to 250
Rainwater/gray water	PH 6.5 < 9.5	300	32 to 250
Chilled water	Ethylene glycol/Propylene glycol*	300	0 to 250
Hydronic heating	Up to 50% Ethylene glycol/Propylene glycol	300	32 to 250
Cooling water	Up to 50% Ethylene glycol/Propylene glycol	300	0 to 250
Fuel oil and lubricant			
Ethanol	Pure grain alcohol	200	Ambient
Gases			
Compressed air	Less than 25mg/m ³ oil content	200	Up to 140
Nitrogen	-	200	Up to 140
Argon	Welding use	200	Up to 140
Vacuum	-	24.5 in Hg	Up to 140
Carbon dioxide - CO2	Dry	200	Up to 140

* Please refer to manufactures instructions.

1.3. Limited Warranty

Conex Universal Ltd. warrants that its >B< Press and >B< Press XL fittings will be free of material defects resulting from errors in manufacture, for fifty (50) years from the date of first purchase by an end user. This warranty will be void if not professionally installed, used and maintained in accordance with the installation and maintenance instructions detailed in the >B< Press and >B< Press XL technical brochure.

THERE ARE NO WARRANTIES WHICH EXTEND BEYOND THIS DESCRIPTION, EXCEPT FOR ANY REQUIREMENTS THAT ARE LEGALLY MANDATED IN THE JURISDICTION OF THE FIRST END USER'S PREMISES. THIS WARRANTY IS LIMITED TO THE REPAIR OR REPLACEMENT OF MATERIALLY DEFECTIVE FITTINGS AT THE SOLE DISCRETION OF CONEX UNIVERSAL LTD.

At the request of Conex Universal Ltd. the claimed defective fitting(s) must be returned to the address opposite*. Conex Universal Ltd. reserves the right to inspect and test claimed defective fittings before deciding whether to repair or replace a fitting claimed to be defective.

This warranty is subject to the following additional conditions:

- A. Any claimed defect(s) must be reported to Conex Universal Ltd. within one month of the first occurrence of any such claimed defect, clearly setting out the nature of the claim and the circumstances surrounding it.
- B. Conex Universal Ltd. shall have no liability in respect of any fitting claimed to be defective if any of the following circumstances apply:
- defective installation;
 - normal wear and tear;
 - wilful misconduct;
 - negligence or omissions of any party other than Conex Universal Ltd.;
 - abnormal working or environmental conditions;
 - failure to follow the installation and maintenance instructions detailed in the >B< Press and >B< Press XL technical brochure, and any other instructions of Conex Universal Ltd. communicated through the Conex Bänninger website or its successor, www.conexbanninger.com (the Website) or otherwise;
 - misuse (which includes any use of the fittings for a purpose or in a situation / environment or for an application other than that for which it was designed according to the specifications of the fittings as described on the website or in other materials provided to the buyer from Conex Universal Ltd.); or
 - alteration or repair of any fitting without the prior written approval of Conex Universal Ltd.

- C. At the request of Conex Universal Ltd., the person claiming under this warranty must deliver to Conex Universal Ltd. written evidence of the date of first purchase by an end user of the products claimed to be defective.

* The address for returns is:

Customer Services at IBP Group LLC. 155 Bartram Market Drive, Suite 135, #163 Saint Johns, FL 32259.

(For returns only):

IBP Group LLC. 5810 Long Prairie Road, Suite 700. #369 Flower Mound, Texas 75028

Note: This warranty applies in the United States of America only.

1.4 Product Suitability

The application parameters referred to in section 1.2 and the tube compatibility tables (section 2.5.5 >B< Press and section 3.3.5 >B< Press XL) must be adhered to when using and connecting >B< Press copper and brass fittings.

1.4.1 Drinking water installations

Drinking water installations must be designed in compliance with the appropriate standards e.g. NSF/ANSI 61 and NSF/ANSI 372 and in line with federal, state and local regulations, codes of practice and by-laws governing the installation. All applicable health and safety practices must be adhered to.

>B< Press and >B< Press XL fittings are IAPMO approved for use in drinking water systems.

1.5 System Commissioning

To ensure the quality and safety of hot and cold water supply systems always follow best practice techniques in their design, installation, commissioning, and maintenance.

Therefore a reliable and predictive regime of commissioning should be in place as governed by the laws and regulations enacted by the federal, state and local governments. Final water test pressure should be carried out at 1.5 x system operating pressure to a maximum of 300 psi

Rain water can be collected for gray water services for example flushing of the toilet. Copper can be used for rain water distribution providing the level of the water is within pH 6.5<9.5.

>B< Press



>B< Press Technical Brochure
1/2" to 2"

2.1 >B< Press Copper Fittings – ½" to 2"

>B< Press fittings are quick and easy to install and are available in copper. This flame-free fitting is designed with an innovative 3-point press system to ensure a leak-free, secure and permanent joint and are suitable for multiple applications.

2.2 Fitting Construction

2.2.1 Fitting construction ½" to 2"

The >B< Press copper design has the advantage of a 3-point press profile; two hexagonal mechanical presses on either side of the bead, and one press on the O-ring. The O-ring material compresses to form a permanent leak proof joint - from Innovation to Installation USA.

>B< Press copper fittings have an 'unpressed joint indicator' that highlights unpressed connections at low pressure. This specifically designed tri-lobal O-ring allows water to pass through and create a small leak when the system is tested at low pressure (1.5 to 85 psi). Any unpressed joints can be identified during the test phase and pressed, saving valuable time and money. There is no need to drain down as the pressing operation can be carried out while the water is still in the system.

For a leak-free joint you must use approved pressing jaws, see section 2.4.3.

>B< Press copper fittings are installed using a press tool with a compatible >B< profile or V profile jaw. Jaws are sized to match the fitting required. When force is exerted through the press tool the jaw closes to make a permanent joint.

Please refer to the approved list of press machines and jaws in section 2.4.3.

2.3 Product Suitability

2.3.1 Compressed air systems

>B< Press fittings with the black EPDM O-ring seal can be used in oil free compressed air systems under the conditions referred to in section 1.2.

2.4 >B< Press Tools

2.4.1 >B< Press jaws

A wide range of industry standard press machines and jaws have been tested for use when installing >B< Press fittings.

Note: we offer press jaws in sizes ½" to 2". See approved press jaws listed in section 2.4.3.

2.4.2 Maintenance ½" to 2"

For maintenance requirements please contact the tool manufacturer.

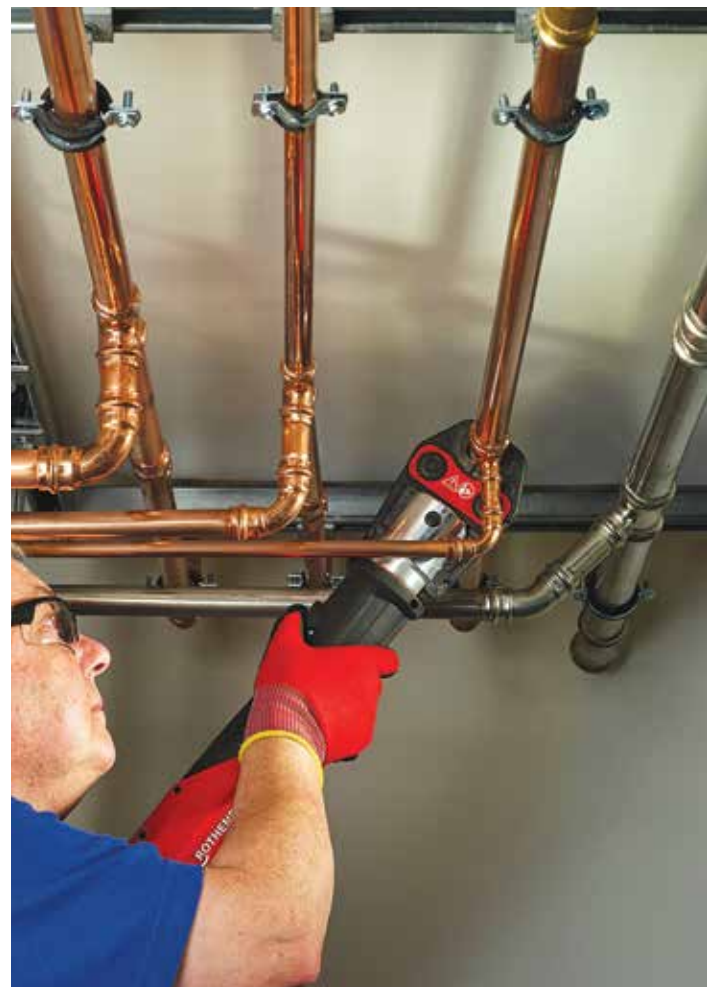

2.4.3 Compatible press tools

Manufacturer	Press machine	Press jaw manufacturer												
		Rothenberger V/SV Profile			"Klauke KSP4"		Milwaukee V Profile (P*)		NIBCO		RIDGID V Profile		Rems V/ V45 Profile	
		Compact	Compact TT	Standard	Mini SBMX	Standard	M12	M18	Mini	Standard	Compact	Standard	Mini	Standard
Rothenberger	Romax Compact	✓			✓									
Rothenberger	Compact TT US		✓								✓			
Rothenberger	Romax 3000			✓		✓		✓		✓		✓		✓
Rothenberger	Romax 4000			✓		✓		✓		✓		✓		✓
Klauke	MAP219 / MAP2L19	✓			✓									
Klauke	UAP2/UAP3L/ UAP332			✓		✓		✓		✓		✓		✓
Milwaukee	M12						✓				✓			
Milwaukee	M18			✓				✓				✓		✓
Nibco	PC-20M								✓					
Nibco	PC-280			✓		✓		✓		✓		✓		✓
Ridgid	RP 200 / 210 / 240 / 241		✓				✓				✓			
Ridgid	CT400			✓		✓		✓		✓		✓		✓
Ridgid	RP 320 / 330 / 340			✓		✓		✓		✓		✓		✓
Rems	Mini Press ACC												✓	
Rems	Power-Press/ Akku-Press			✓		✓		✓		✓		✓		✓

*Milwaukee press jaws must be marked with a . Please contact technical@ibpgroup.com for other tool and jaws compatibility.

! Always read the manufacturers instruction book before using press machines and jaws. When using a press tool always wear ear and eye protection.

2.4.4 Use of tools

If other machines and press jaws are used, their suitability for a permanent leak proof connection must be demonstrated by an accredited test. A constant thrust of at least 32 kN and max. 36 kN is a prerequisite to ensure that sufficient power reserves for the dimension of 2" are available, and that high shear forces cannot reduce the lifetime of the pressing jaws or destroy them.

2.5 Installation Requirements

2.5.1 Space required for the pressing process

The following minimum clearances are required from structural components to allow operation of tool for press fitting.

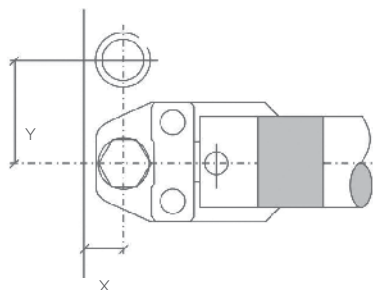

Space required for the pressing process between pipes		
External pipe	X	Y
Size inch	inch	inch
½	1.02	2.09
¾	1.02	2.20
1	1.30	2.32
1¼	1.30	2.87
1½	2.95	4.53
2	3.35	4.72

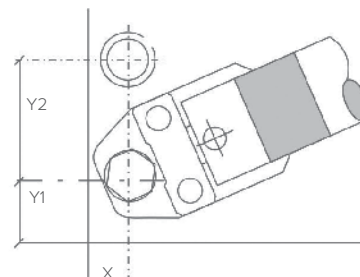

Space required for the pressing process between tubes			
External pipe	X	Y1	Y2
Size inch	inch	inch	inch
½	1.22	1.77	2.87
¾	1.22	1.77	2.99
1	1.50	2.17	3.15
1¼	1.50	2.17	3.35
1½	2.95	2.95	4.53
2	3.35	3.35	5.51

2.5.2 Insertion depth and minimum distances between pressings

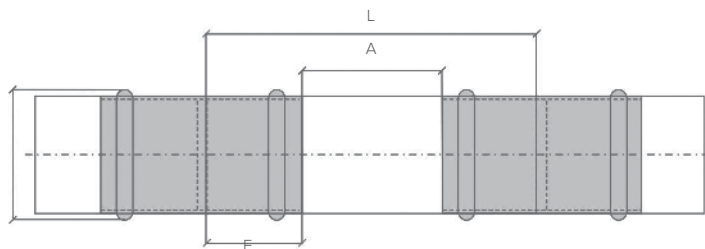

Insertion depth and minimum distance between pressings			
Size	Minimum distance	Minimum tube length	Insertion depth
inch	A - inch	L - inch	E - inch
½	0.39	1.89	0.75
¾	0.79	2.60	0.91
1	0.79	2.60	0.91
1¼	0.98	3.03	1.02
1½	1.18	4.02	1.42
2	1.38	4.53	1.57

Due to reforming of the tube profile when pressed, it is advised that a minimum distance is allowed between each fitting.

2.5.3 Minimum distance for press fittings from an existing brazed joint

To ensure proper sealing of both the brazed and >B<Press fitting, the following minimum distances must be maintained between the two fittings. Please see table A for further information.

Table A

Minimum distance from a brazed joint	
Tube size	inch
½"	0.4"
¾"	0.8"
1"	0.8"
1¼"	1.0"
1½"	1.2"
2"	1.4"

2.5.4 Minimum brazing distance to an existing pressed fitting

Caution: Brazing or soldering near to >B< Press joints should be avoided as this may cause the seal to degrade due to heat transfer. Table B states the minimum distance away from the press joint which is acceptable to braze. If this distance cannot be maintained then adequate precautions must be taken such as fabricating the brazed section prior to assembly with the press fittings, wrapping in a wet rag or applying a hot block, to prevent heat transfer to the press fitting during brazing.

Table B

Minimum distance brazing	
Tube size	inch
½"	18"
¾"	24"
1"	30"
1¼"	36"
1½"	48"
2"	60"

2.5.5 >B< Press tube compatibility table

Nominal or standard size (inches)	Outside diameter (inches)	Average outside diameterA tolerance (inches)		Wall thickness and tolerances (inches)					
				Type K		Type L		Type M	
		Annealed	Drawn	Wall thickness	ToleranceB	Wall thickness	ToleranceB	Wall thickness	ToleranceB
¼	0.375	0.002	0.001	0.035	0.0035	0.030	0.003	C	C
⅜	0.500	0.0025	0.001	0.049	0.005	0.035	0.004	0.025	0.002
½	0.625	0.0025	0.001	0.049	0.005	0.040	0.004	0.028	0.003
⅝	0.750	0.0025	0.001	0.049	0.005	0.042	0.004	C	C
¾	0.875	0.003	0.001	0.065	0.006	0.045	0.004	0.032	0.003
1	1.125	0.0035	0.0015	0.065	0.006	0.050	0.005	0.035	0.004
1¼	1.375	0.004	0.0015	0.065	0.006	0.055	0.006	0.042	0.004
1½	1.625	0.0045	0.002	0.072	0.007	0.060	0.006	0.049	0.005
2	2.125	0.005	0.002	0.083	0.008	0.070	0.007	0.058	0.006

A - The average outside diameter of a tube is the average of the maximum and minimum outside diameter, as determined at any one cross section of the tube.

B - Maximum deviation at any one point

C- Indicated that the material is not generally available or that no tolerance has been established

2.6 >B< Press Installation Process

Leave the fittings in the packaging prior to final installation to protect them from contamination and to preserve the lubrication of the O-rings. Please note the space required for pressing tools (see section 2.5.1).



1. Cut tube to length

- Use a rotary tube cutter.
- Ensure that the tube is cut square.
- Check the tube has retained its shape and is damage free.



2. Deburr

- Deburr the tube both internally and externally.
- Where possible angle the tube downwards to prevent filings entering the tube.
- Make sure the internal and external surfaces of the tube ends are smooth and free from burrs or sharp edges.

Caution: Please ensure that the tube surface is free from any deep scores or scratches.

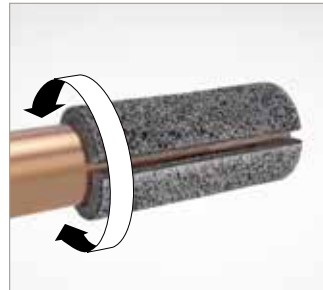

3. Clean the tube

- Thoroughly clean the tube end using a rovlie or similar cleaning pad in a rotating action.
- Tube ends must be free from scratches, oxidation, dirt and debris.



4. Check for scratches and scores

- If deep scratches are still visible, cut the tube back to a clean section and prepare the tube end again.



5. Check the fittings

- Check the fitting is the correct size for the tube.
- Check the O-rings are present and correctly seated.
- Additional >B< Press lubricant (silicon oil) may be used to aid tube insertion. (MPABPSOIL100ML)



6. Assemble and mark the insertion depth

- The tube must be fully inserted into the fitting until it reaches the tube stop.
- To reduce the risk of dislodging the O-ring, rotate the tube (if possible) while slipping it into the fitting.
- Mark the insertion depth on the tube.
- Prior to pressing ensure the tube has not moved out from the fitting socket.



7. Complete the joint with the press tool





















- Ensure pipework is correctly aligned prior to pressing.
- Ensure the correct size jaw is inserted into the tool.
- The jaws must be placed squarely on the fitting, locating the groove on the bead.
- The bead on the fitting should fit centrally in the groove of the jaw.
- Depress and hold the start button on the press tool to complete the pressing cycle.
- Pressing is complete when the jaws are fully closed.
- Complete the press cycle once only – do not re-press.



8. Mark the completed joint

- Mark the completed joint after pressing.
- This enables joints to be inspected easily before testing.

2.7 Product Range - From Innovation to Installation USA

Straight Coupler  PA5270	Reduced Straight Coupler  PA5240	Slip Coupler  PA5270S	Female Straight Connector  PA5270G	Male Straight Connector  PA5243G
90° Bend  PA5002	90° Street Bend  PA5001	Fitting Reducer  PA5243	90° Bend with Male Thread  PA5001G	90° Elbow with Female Thread  PA5090G
45° Obtuse Elbow  PA5041	45° Obtuse Street Elbow  PA5040	Tee - Equal  PA5130	Tee - Reduced Branch  PA5130RB	Tee - Reduced End and Branch  PA5130REB
Tee with Female Threaded Branch  PA5130G	Stop End  PA5301	Wall Plate Elbow  PA4471G	Crossover  PA5085	Union  PA4340
Male Union  PA4341G	Female Union  PA4340G			

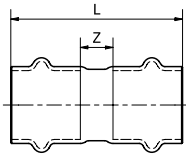
PA5270		Straight Coupler			
	Dimension	L	Z	Product code	
	1/2	1.77	0.28	PA5270 00400000	
	3/4	2.22	0.41	PA5270 00600000	
	1	2.22	0.41	PA5270 00800000	
	1 1/4	2.44	0.39	PA5270 01000000	
	1 1/2	3.31	0.47	PA5270 01200000	
	2	3.62	0.47	PA5270 01600000	

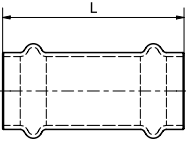
PA5270S		Slip Coupler			
	Dimension	L	Product code		
	1/2	1.77	PA5270S00400000		
	3/4	2.22	PA5270S00600000		
	1	2.22	PA5270S00800000		
	1 1/4	2.44	PA5270S01000000		
	1 1/2	3.31	PA5270S01200000		
	2	3.62	PA5270S01600000		

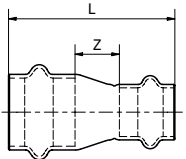
PA5240		Reduced Straight Coupler			
	Dimension	L	Z	Product code	
	3/4 x 1/2	2.05	0.39	PA5240 0060400	
	1 x 3/4	2.24	0.43	PA5240 0080600	
	1 1/4 x 1	2.44	0.51	PA5240 0100800	
	1 1/2 x 1	3.03	0.71	PA5240 0120800	
	2 x 1	3.62	1.14	PA5240 0160800	
	2 x 1 1/4	3.62	1.02	PA5240 0161000	
	2 x 1 1/2	3.77	0.78	PA5240 0161200	

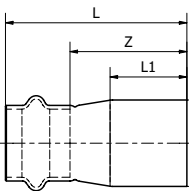
PA5243		Fitting Reducer			
	Dimension	L	L1	Z	Product code
	3/4 x 1/2	2.05	1.30	0.31	PA5243 0060400
	1 x 1/2	2.52	1.77	0.79	PA5243 0080400
	1 x 3/4	2.20	1.30	0.31	PA5243 0080600
	1 1/4 x 1	2.56	1.65	0.55	PA5243 0100800
	1 1/2 x 1	3.11	2.20	0.71	PA5243 0120800
	1 1/2 x 1 1/4	3.11	2.09	0.59	PA5243 0121000
	2 x 1	3.82	2.91	1.26	PA5243 0160800
	2 x 1 1/2	3.82	2.28	0.75	PA5243 0161200

*All above measurements are in inches unless stated differently.

PA5243G

Male Straight Connector

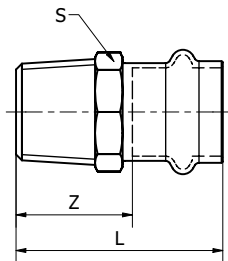

Dimension	L	S	Z	Product code
1/2 x 1/2	1.85	0.87	1.10	PA5243G0040400
1/2 x 3/4	2.60	1.10	1.88	PA5243G0040600
3/4 x 1/2	2.60	0.87	1.73	PA5243G0060400
3/4 x 3/4	2.17	1.10	1.26	PA5243G0060600
3/4 x 1	2.91	1.34	2.01	PA5243G0060800
1 x 3/4	2.72	1.10	1.85	PA5243G0080600
1 x 1	2.36	1.34	1.46	PA5243G0080800
1 x 1 1/4	3.11	1.69	2.27	PA5243G0081000
1 1/4 x 1	3.15	1.34	2.16	PA5243G0100800
1 1/4 x 1 1/4	2.62	1.69	1.59	PA5243G0101000
1 1/4 x 1 1/2	3.31	1.97	2.35	PA5243G0101200
1 1/2 x 1 1/4	3.01	1.69	1.59	PA5243G0121000
1 1/2 x 1 1/2	3.07	1.97	1.65	PA5243G0121200
2 x 2	3.27	2.68	1.69	PA5243G0161600

PA5270G

Female Straight Connector

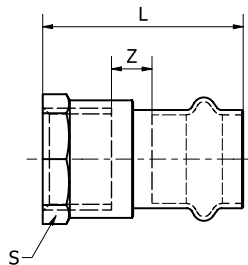

Dimension	L	Z	S	Product code
1/2 x 1/2	1.73	0.39	1.02	PA5270G0040400
1/2 x 3/4	2.44	1.09	1.20	PA5270G0040600
3/4 x 1/2	2.48	1.00	1.02	PA5270G0060400
3/4 x 3/4	2.01	0.37	1.20	PA5270G0060600
3/4 x 1	2.66	1.00	1.46	PA5270G0060800
1 x 1/2	2.48	1.02	1.02	PA5270G0080400
1 x 3/4	2.56	0.96	1.20	PA5270G0080600
1 x 1	2.11	0.45	1.46	PA5270G0080800
1 1/4 x 1	2.87	1.14	1.46	PA5270G0100800
1 1/4 x 1 1/4	2.28	0.49	1.85	PA5270G0101000
1 1/2 x 1 1/4	2.68	0.49	1.85	PA5270G0121000
1 1/2 x 1 1/2	2.80	0.61	2.09	PA5270G0121200
2 x 2	2.91	0.59	2.76	PA5270G0161600

PA4340

Union

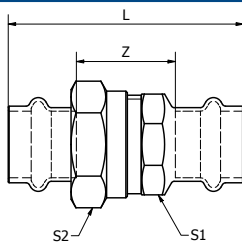

Dimension	L	Z	S1	S2	Product code
1/2 x 1/2	2.78	1.28	1.10	1.18	PA4340 0040400
3/4 x 3/4	3.13	1.32	1.34	1.46	PA4340 0060600
1 x 1	3.58	1.77	1.81	1.69	PA4340 0080800
1 1/4 x 1 1/4	3.82	1.77	2.09	1.99	PA4340 0101000
1 1/2 x 1 1/2	5.00	2.40	2.58	2.68	PA4340 0121200
2 x 2	5.31	2.17	3.29	2.99	PA4340 0161600

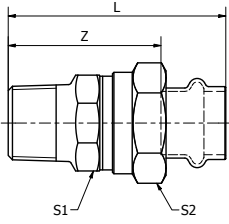
PA4341G		Male Straight Union Connector				
	Dimension	L	Z	S1	S2	Product code
	1/2 x 1/2	2.81	2.07	1.06	1.18	PA4341G0040400
	3/4 x 3/4	3.04	2.13	1.34	1.46	PA4341G0060600
	1 x 1	3.78	2.87	1.65	1.81	PA4341G0080800
	1 1/4 x 1 1/4	3.76	2.74	1.97	2.09	PA4341G0101000
	1 1/2 x 1/2	4.71	3.40	2.68	2.58	PA4341G0121200
	2 x 2	4.80	3.22	2.99	3.29	PA4341G0161600

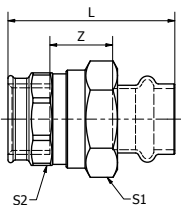
PA4340G		Male Union				
	Dimension	L	Z	S1	S2	Product code
	1/2 x 1/2	2.24	0.90	1.18	1.10	PA4340G0040400
	3/4 x 3/4	2.43	0.91	1.46	1.34	PA4340G0060600
	1 x 1	2.83	1.14	1.81	1.69	PA4340G0080800
	1 1/4 x 1 1/4	3.01	1.20	2.09	1.97	PA4340G0101000
	1 1/2 x 1/2	3.87	1.68	2.58	2.68	PA4340G0121200
	2 x 2	4.05	1.49	3.29	2.99	PA4340G0161600

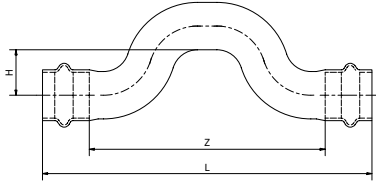
PA5085		Crossover Coupler			
	Dimension	L	Z	H	Product code
	1/2 x 1/2	5.13	3.63	0.77	PA5085 0040000
	3/4 x 3/4	6.38	4.56	0.89	PA5085 0060000

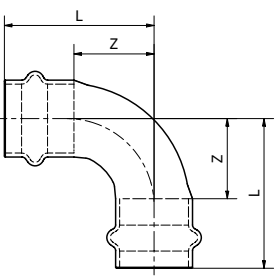
PA5002		90° Bend			
	Dimension	L	Z		Product code
	1/2	1.50	0.75		PA5002 0040000
	3/4	1.95	1.04		PA5002 0060000
	1	2.24	1.34		PA5002 0080000
	1 1/4	2.68	1.65		PA5002 0100000
	1 1/2	3.43	2.01		PA5002 0120000
	2	4.13	2.56		PA5002 0160000

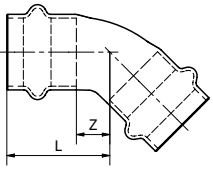
PA5041		45° Obtuse Elbow			
	Dimension	L	Z		Product code
	1/2	1.06	0.31		PA5041 0040000
	3/4	1.34	0.43		PA5041 0060000
	1	1.50	0.59		PA5041 0080000
	1 1/4	1.73	0.71		PA5041 0100000
	1 1/2	2.24	0.83		PA5041 0120000
	2	2.64	1.06		PA5041 0160000

*All above measurements are in inches unless stated differently.

PA5001G 90° Bend with Male Thread

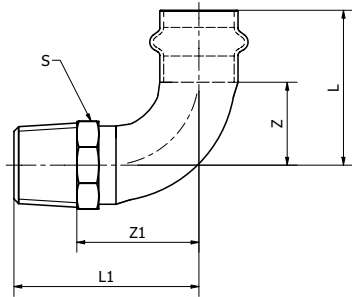

Dimension	L	L1	Z	Z1	S	Product code
1/2 x 1/2	1.50	1.91	0.77	1.16	0.87	PA5001G0040400
3/4 x 3/4	1.95	2.32	1.04	1.53	1.10	PA5001G0060600
1 x 1	2.20	2.81	1.30	1.83	1.34	PA5001G0080800
1 1/4 x 1 1/4	2.68	3.31	1.65	2.32	1.69	PA5001G0101000
1 1/2 x 1 1/2	3.41	3.70	2.01	2.70	1.97	PA5001G0121200
2 x 2	4.17	4.53	2.62	3.48	2.68	PA5001G0161600

PA5090G 90° Elbow with Female Thread

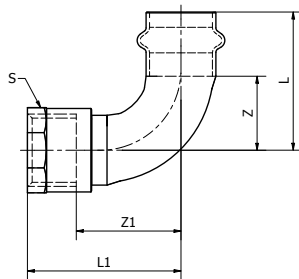

Dimension	L	L1	Z	Z1	S	Product code
1/2 x 1/2	1.50	1.71	0.77	1.08	1.02	PA5090G0040400
3/4 x 3/4	1.95	2.17	1.04	1.48	1.20	PA5090G0060600
1 x 1	2.20	2.54	1.30	1.69	1.46	PA5090G0080800
1 1/4 x 1 1/4	2.68	2.95	1.65	2.09	1.85	PA5090G0101000
1 1/2 x 1 1/2	3.41	3.43	2.01	2.56	2.09	PA5090G0121200
2 x 2	4.19	4.00	2.62	3.13	2.76	PA5090G0161600

PA4471G Wallplate Elbow (3 Hole) with Female Thread

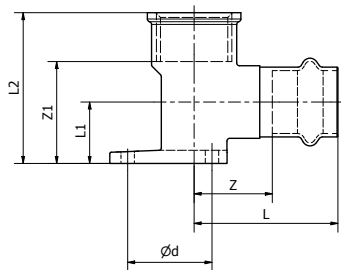

Dimension	L	L1	L2	d	Z	Z1	Product code
1/2 x 1/2	1.89	0.75	1.76	1.50	0.94	1.10	PA4471G0040400
3/4 x 3/4	2.03	0.75	2.13	1.87	1.12	1.87	PA4471G0060600

PA5001 90° Street Bend

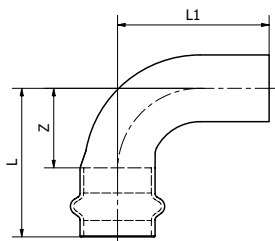

Dimension	L	L1	Z	Product code
1/2	1.48	1.57	0.72	PA5001 0040000
3/4	1.95	2.04	1.04	PA5001 0060000
1	2.23	2.24	1.32	PA5001 0080000
1 1/4	2.67	2.75	1.65	PA5001 0100000
1 1/2	3.42	3.50	2.00	PA5001 0120000
2	4.19	4.13	2.62	PA5001 0160000

PA5040		45° Obtuse Street Elbow			
Dimension	L	L1	Z	Product code	
½	1.06	1.14	0.31	PA5040 0040000	
¾	1.34	1.42	0.43	PA5040 0060000	
1	1.50	1.57	0.59	PA5040 0080000	
1¼	1.73	1.81	0.71	PA5040 0100000	
1½	2.24	2.32	0.83	PA5040 0120000	
2	2.64	2.72	1.06	PA5040 0160000	

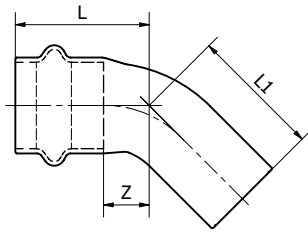

PA5130		Tee - Equal			
Dimension	L	Z	L1	Z1	Product code
½	2.99	0.75	1.22	0.47	PA5130 0040000
¾	3.50	0.85	1.54	0.63	PA5130 0060000
1	3.74	0.96	1.69	0.79	PA5130 0080000
1¼	4.13	1.04	1.89	0.87	PA5130 0100000
1½	5.12	1.14	2.56	1.14	PA5130 0120000
2	5.91	1.38	2.95	1.38	PA5130 0160000

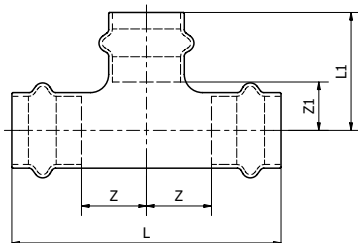

PA5130RB		Tee - Reduced Branch			
Dimension	L	Z	L1	Z1	Product code
¾ x ¾ x ½	3.23	0.71	1.40	0.63	PA5130 0060406
1 x 1 x ½	3.61	0.87	1.69	0.78	PA5130 0080408
1 x 1 x ¾	3.54	0.87	1.69	0.79	PA5130 0080608
1¼ x 1¼ x 1	3.82	0.88	1.81	0.87	PA5130 0100810
1½ x 1½ x ½	4.02	0.59	1.42	1.14	PA5130 0120412
1½ x 1½ x ¾	4.17	0.67	2.09	1.14	PA5130 0120612
1½ x 1½ x 1	4.18	0.75	2.09	1.14	PA5130 0120812
2 x 2 x 1	4.88	0.87	2.28	1.38	PA5130 0160816
2 x 2 x 1¼	5.28	1.06	2.40	1.38	PA5130 0161016
2 x 2 x 1½	5.42	1.14	2.78	1.37	PA5130 0161216

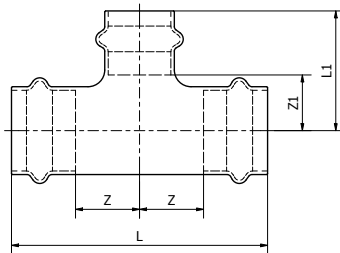

PA5130		Tee - Reduced End and Branch					
Dimension	L	Z	L1	Z1	L2	Z2	Product code
½ x ½ x ¾	1.77	0.91	1.38	0.47	1.77	0.91	PA5130 0040604
¾ x ½ x ½	1.59	0.69	1.40	0.63	1.78	1.04	PA5130 0060404
¾ x ½ x ¾	1.75	0.85	1.71	0.79	1.93	1.02	PA5130 0060604
¾ x ¾ x 1	1.91	2.00	1.58	0.63	1.91	1.00	PA5130 0060806
1 x ¾ x ¾	1.77	0.87	1.71	0.79	1.93	1.02	PA5130 0080606

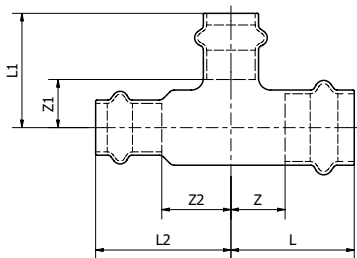

*All above measurements are in inches unless stated differently.

PA5130G

Tee with Female Threaded Branch

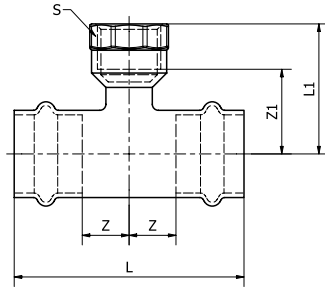

Dimension	L	Z	L1	Z1	S	Product code
1/2 x 1/2 x 1/2 FI	2.99	0.75	1.42	0.81	1.02	PA5130G0040404
3/4 x 3/4 x 1/2 FI	3.19	0.69	1.61	0.98	1.20	PA5130G0060406
1 x 1 x 1/2 FI	3.31	0.75	1.77	1.14	1.45	PA5130G0080408
1 1/2 x 1 1/2 x 1/2 FI	3.86	0.63	2.17	1.54	1.85	PA5130G0120412
2 x 2 x 1/2 FI	4.65	0.75	2.38	1.75	2.09	PA5130G0160416

PA5301

Stop End

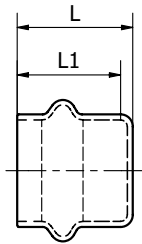

Dimension	L	L1	Product code
1/2	0.94	0.75	PA5301 0040000
3/4	1.10	0.91	PA5301 0060000
1	1.10	0.91	PA5301 0080000
1 1/4	1.26	1.02	PA5301 0100000
1 1/2	1.65	1.42	PA5301 0120000
2	1.81	1.57	PA5301 0160000

>B< Press XL



>B< Press XL Technical Brochure
2 ½" to 4"

>B< Press XL

3.1 >B< Press XL Copper Fittings – 2 ½" to 4"

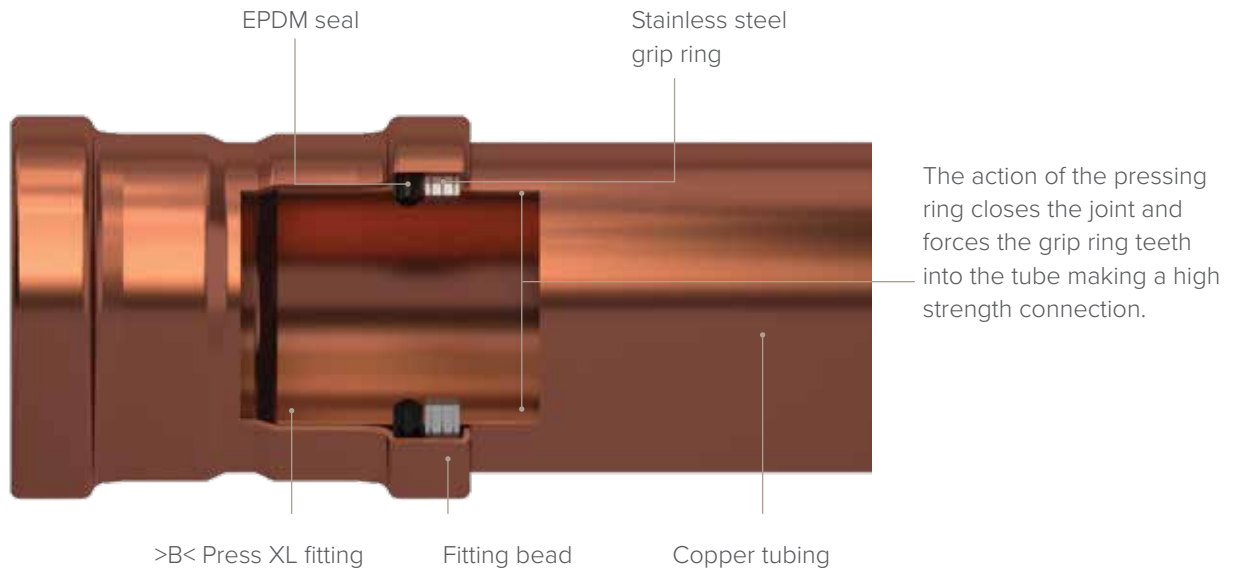

3.1.1 Product features

>B< Press XL has only two internal parts, the grip ring and the seal. Both parts have an internal diameter larger than the tube, which allows for easy tube insertion and prepress leak indication.

3.1.2 Stainless steel grip ring

Full circumference grip ring ensures all round equal grip on the tube and an even seal compression between tube and fitting after pressing.



Stainless steel grip ring

3.1.3 Seal design

Triple point seal on the pressed fitting body counters any pressing distortion and gives greater seal contact area on the tube. The seal is self setting to ensure correct functioning. Seal security and longevity increased as a result.



Fitting section



Triple point seal

3.2 Compatible Press Tools

3.2.1 Tool chart

Manufacturer	Press machine	Press jaw manufacturer		
		RIDGID XL-C + V2 Profile	Milwaukee CTS-V + r1 Ring Jaw	REMS VUSF _Z + Z5
Milwaukee	M18	✓	✓	✓
Rems	Power-Press/ Akku-Press	✓	✓	✓
Ridgid	CT400	✓	✓	✓
Ridgid	RP 320 / 330 / 340	✓	✓	✓
Rothenberger	Romax 4000	✓	✓	✓

3.3 Installation Requirements

3.3.1 Space required for the pressing process

The following minimum clearances from structural components are required to allow operation of tool for press fitting.

Size	Minimum clearance required for the pressing process				
	A	B	C	D	E
2 ½"	3.94"	5.71"	3.94"	3.94"	6.50"
3"	4.72"	6.69"	4.72"	4.92"	7.48"
4"	5.31"	7.87"	5.31"	5.71"	9.06"

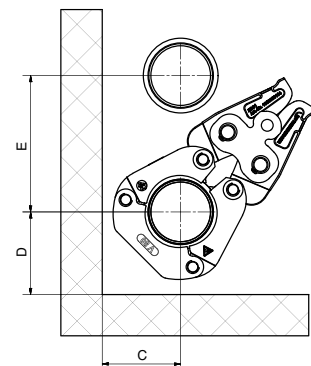
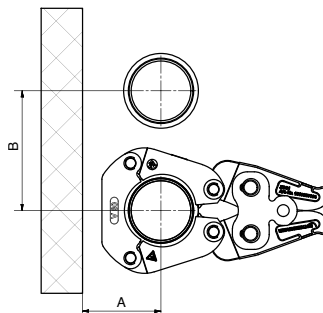
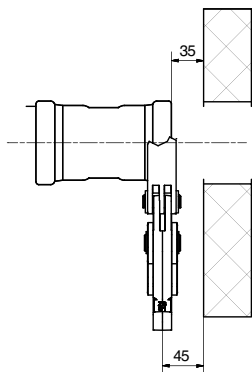

>B< Press XL

3.3.2 Minimum distances between pressings

Due to reforming of the tube profile when pressed, it is advised that a minimum distance is allowed between each fitting.

Size	D	E	F	G
2 ½"	3.17"	1.73"	1.18"	4.65"
3"	3.69"	1.91"	1.57"	5.39"
4"	4.69"	2.30"	1.97"	6.57"

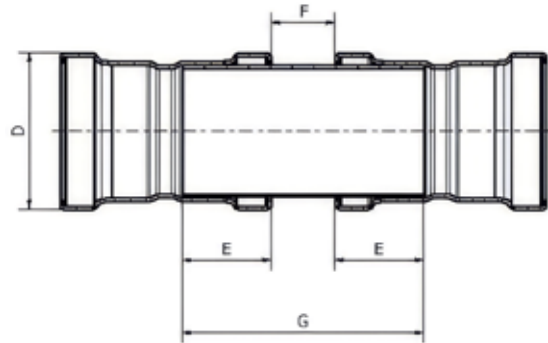

3.3.3 Minimum distance for press fittings from an existing brazed joint

To ensure proper sealing of both brazed and >B< Press fittings, the following minimum distances must be maintained. Please see table A for further information.

Table A

Minimum distance from a brazed joint	
Tube size	inch
2 ½"	1.18"
3"	1.77"
4"	1.97"

3.3.4 Minimum brazing distance to an existing pressed fitting

Caution: Brazing or soldering near >B< Press joints should be avoided as this may cause the seal to degrade due to heat transfer. Table B below states the minimum distance away from the press joint acceptable to braze. If this distance cannot be maintained then adequate precautions must be taken such as fabricating the brazed section prior to assembly with the press fittings, wrapping in a wet rag or applying a hot block, to prevent heat transfer to the press fitting during brazing.

Table B

Minimum distance brazing	
Tube size	Ft
2 ½"	5.25'
3"	6.55'
4"	6.55'

3.3.5 >B< Press XL tube compatibility table

Copper tube compatibility table ASTM B88						
Tube O/D	Soft			Hard		
	Type K	Type L	Type M	Type K	Type L	Type M
2 ½"	-	-	-	✓	✓	✓
3"	-	-	-	✓	✓	✓
4"	-	-	-	✓	✓	✓



3.4 >B< Press XL Installation Process

To install >B< Press XL, a press tool, actuator and compatible sized press ring to fit each size fitting is required. When pressure is exerted through the press tool a permanent joint is made and the fitting cannot be disassembled or reused.



1. Cut tube to length

- We recommend you use a rotary tube cutter. It is important to ensure that the tube is cut completely square.
- Tube ends should be clean and free from scratches no less than the socket length.

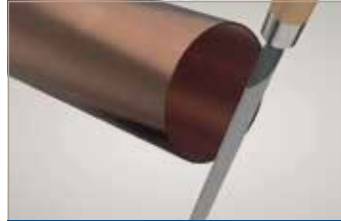

2. Deburr

- Make sure that the internal and external tube end is free from burrs or sharp edges by using a half round file or deburring tool.
- Then wipe the tube end clean to avoid damaging the seal on tube insertion.

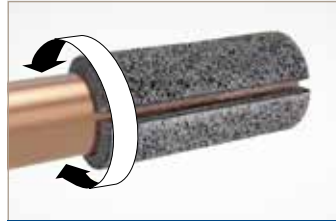

3. Clean the tube

- Thoroughly clean the tube end using a rovlie or similar cleaning pad in a rotating action.
- Tube ends must be free from scratches, oxidation, dirt and debris.



4. Check for scratches & scores

- If deep scratches are still visible, cut the tube back to a clean section and prepare the tube end again.



5. Check the fittings

- Before inserting the tube check seal for correct placement, damage or any ingress of debris.
- To prevent this occurring we recommend the fittings are retained in packaging up to the point of use.
- **Follow label instructions and remove it before tube insertion.**



6. Mark the insertion depth

- The tube must be correctly aligned when inserted into the fitting. Insert the tube until reaching the tube stop in order to make the perfect joint.
- Marking insertion depth will ensure that any tube movement is detected, which is especially important if the joints are to be pressed at a later time.
- The depth marking must be visible on the pressed fitting.

Size	Insertion Depth
2½"	1.73"
3"	1.91"
4"	2.30"



7. Fit the pressing ring

- Using the appropriate size pressing ring, open the pressing ring, locate on the fitting bead and close the pressing ring.



8. Engage the actuator and check insertion depth

- With the actuator fitted in the press tool open the actuator and insert the actuator into the slot of the press ring.
- Check for any tube movement prior to pressing.



9. Press the joint

- Depress and hold the trigger of the tool until the press cycle of the tool is automatically completed. Keep hands clear of the press actuator and press ring until the cycle is completed.
- Do not repress the fitting.

















10. Joint completion

- Remove the actuator from the press ring, remove the press ring from the tube and remove the label to indicate the joint is pressed and complete.

Important

It is important to keep the fitting free of any dust or dirt, and to ensure the seal stays lubricated and protected from damage. Select the correct size of tube and fitting for the job. Ensure that both are clean and free from damage and imperfections. When using a press tool always wear ear and eye protection.

3.5 Product Range - From Innovation to Installation USA

<p>Straight Connector</p>	<p>Repair Coupling</p>	<p>Fitting Reducer</p>	<p>Male Threaded Straight Connector</p>
			
<p>PA5270</p>	<p>PA5275</p>	<p>PA5243</p>	<p>PA5243G</p>
<p>Threaded Female Straight Connector</p>	<p>90° Elbow</p>	<p>90° Street Elbow</p>	<p>45° Elbow</p>
			
<p>PA5270G</p>	<p>PA5002</p>	<p>PA5001</p>	<p>PA5041</p>
<p>45° Street Elbow</p>	<p>Tee - Equal</p>	<p>Tee - Reduced Branch</p>	<p>Tee - Reduced End and Branch</p>
			
<p>PA5040</p>	<p>PA5130</p>	<p>PA5130RB</p>	<p>PA5130REB</p>
<p>Tee with Female Threaded Branch</p>	<p>Stop End</p>		
			
<p>PA5130G</p>	<p>PA5301</p>		

>B< Press XL x threaded fittings are either NPT(M) for male or FPT(F) for female internal threads.

PA5270 Straight Connector

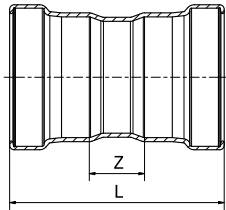

Dimension	L	Z	Product code
2 ½	4.57	1.10	PA5270 02000000
3	4.61	0.79	PA5270 02400000
4	5.39	0.79	PA5270 03200000

PA5275 Repair Coupling

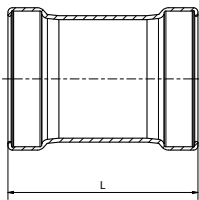

Dimension	L	Product code
2 ½	4.21	PA5275 02000000
3	4.61	PA5275 02400000
4	5.39	PA5275 03200000

PA5243 Fitting Reducer

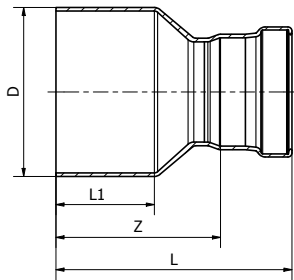

Dimension	D	L	L1	Z	Product code
2 ½ x 1	2 ½	4.17	1.69	3.27	PA5243 0200800
2 ½ x 1 ¼	2 ½	4.17	1.69	3.15	PA5243 0201000
2 ½ x 1 ½	2 ½	4.41	1.69	2.99	PA5243 0201200
2 ½ x 2	2 ½	4.37	1.69	2.80	PA5243 0201600
3 x 1 ¼	3	4.57	1.97	3.66	PA5243 0241000
3 x 1 ½	3	4.84	1.97	3.43	PA5243 0241200
3 x 2	3	4.72	1.97	3.15	PA5243 0241600
3 x 2 ½	3	4.76	1.97	3.03	PA5243 0242000
4 x 2	4	5.71	2.36	4.13	PA5243 0321600
4 x 2 ½	4	5.75	2.36	4.02	PA5243 0322000
4 x 3	4	5.65	2.36	3.74	PA5243 0322400

PA5243G Male Threaded Straight Connector

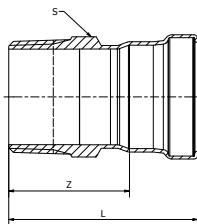

Dimension	L	Z	S	Product code
2 ½	4.61	2.87	3.07	PA5243G0200000
3	4.86	2.95	3.74	PA5243G0240000
4	5.61	3.31	4.72	PA5243G0320000

PA5270G Female Threaded Straight Connector

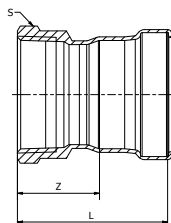

Dimension	L	Z	S	Product code
2 ½	3.50	1.77	3.15	PA5270G0200000
3	3.88	1.97	3.94	PA5270G0240000
4	4.39	2.09	4.92	PA5270G0320000

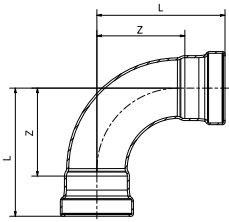
PA5002		90° Elbow			
	Dimension	L	Z	Product code	
	2 1/2	5.55	3.82	PA5002 02000000	
	3	6.83	4.92	PA5002 02400000	
	4	8.60	6.30	PA5002 03200000	

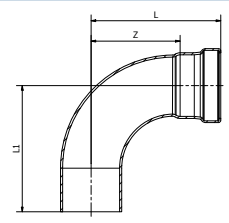
PA5001		90° Street Elbow			
	Dimension	L	L1	Z	Product code
	2 1/2	5.55	5.39	3.82	PA5001 02000000
	3	6.83	6.79	4.92	PA5001 02400000
	4	8.60	8.58	6.30	PA5001 03200000

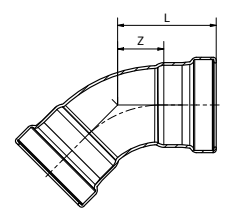
PA5041		45° Elbow			
	Dimension	L	Z	Product code	
	2 1/2	3.27	1.54	PA5041 02000000	
	3	3.88	1.97	PA5041 02400000	
	4	5.14	2.83	PA5041 03200000	

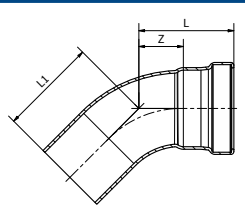
PA5040		45° Street Elbow			
	Dimension	L	L1	Z	Product code
	2 1/2	3.27	3.37	1.54	PA5040 02000000
	3	3.88	4.09	1.97	PA5040 02400000
	4	5.14	5.08	2.83	PA5040 03200000

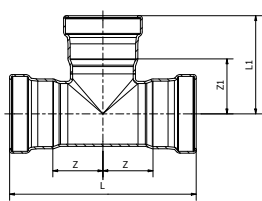
PA5130		Equal Tee				
	Dimension	L	L1	Z	Z1	Product code
	2 1/2	7.52	3.74	2.01	2.20	PA5130 02000000
	3	7.95	4.27	2.07	2.36	PA5130 02400000
	4	9.88	5.35	2.68	3.05	PA5130 03200000

*All above measurements are in inches unless stated differently.

PA5130RB

Tee - Reduced Branch

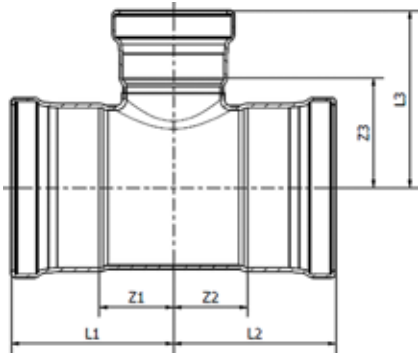

Dimension	L1	L2	L3	Z1	Z2	Z3	Product code
2½ x 2½ x ½	2.52	2.52	2.25	0.79	0.79	1.50	PA5130 0200420
2½ x 2½ x ¾	2.69	2.69	2.59	0.95	0.95	1.68	PA5130 0200620
2½ x 2½ x 1	3.09	3.09	2.39	1.36	1.36	1.48	PA5130 0200820
2½ x 2½ x 1¼	2.95	2.95	2.55	1.22	1.22	1.52	PA5130 0201020
2½ x 2½ x 1½	3.03	3.03	2.94	1.30	1.30	1.52	PA5130 0201220
2½ x 2½ x 2	3.29	3.29	3.14	1.56	1.56	1.56	PA5130 0201620
3 x 3 x ½	2.81	2.81	2.56	0.89	0.89	1.81	PA5130 0240424
3 x 3 x ¾	2.90	2.90	2.87	0.97	0.97	1.97	PA5130 0240624
3 x 3 x 1	3.09	3.09	2.76	1.16	1.16	1.85	PA5130 0240824
3 x 3 x 1¼	3.17	3.17	2.83	1.24	1.24	1.81	PA5130 0241024
3 x 3 x 1½	3.29	3.29	3.27	1.36	1.36	1.85	PA5130 0241224
3 x 3 x 2	3.54	3.54	3.43	1.61	1.61	1.85	PA5130 0241624
3 x 3 x 2½	3.78	3.78	3.90	1.85	1.85	2.17	PA5130 0242024
4 x 4 x ½	3.48	3.48	3.27	0.96	0.96	2.52	PA5130 0320432
4 x 4 x ¾	3.48	3.48	3.27	0.96	0.96	2.36	PA5130 0320632
4 x 4 x 1	3.64	3.64	3.19	1.12	1.12	2.28	PA5130 0320832
4 x 4 x 1¼	3.72	3.72	3.31	1.20	1.20	2.28	PA5130 0321032
4 x 4 x 1½	3.86	3.86	3.74	1.34	1.34	2.32	PA5130 0321232
4 x 4 x 2	4.09	4.09	3.94	1.57	1.57	2.36	PA5130 0321632
4 x 4 x 2½	4.25	4.25	4.45	1.73	1.73	2.72	PA5130 0322032
4 x 4 x 3	4.47	4.47	4.57	1.95	1.95	2.64	PA5130 0322432

PA5130REB

Tee - Reduced End and Branch

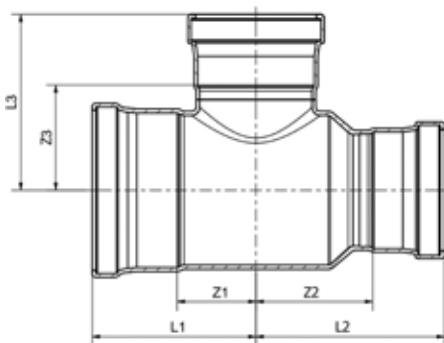

Dimension	L1	L2	L3	Z1	Z2	Z3	Product code
2½ x 2 x ¾	3.19	2.95	2.59	1.46	1.38	1.68	PA5130 0200616
2½ x 2 x 1	3.13	3.29	2.47	1.40	1.71	1.56	PA5130 0200816
2½ x 2½ x 1	3.09	3.09	2.39	1.36	1.36	1.48	PA5130 0200820
2½ x 2 x 1½	3.05	3.48	2.94	1.32	1.91	1.52	PA5130 0201216
2½ x 2 x 2	3.56	3.96	3.14	1.83	2.38	1.56	PA5130 0201616
2½ x ¾ x 2½	3.68	3.80	3.61	1.95	2.89	1.88	PA5130 0202006
2½ x 1 x 2½	3.68	3.80	3.61	1.95	2.89	1.88	PA5130 0202008
2½ x 1¼ x 2½	3.64	3.92	3.61	1.91	2.89	1.88	PA5130 0202010
2½ x 1½ x 2½	3.68	4.11	3.65	1.95	2.70	1.92	PA5130 0202012
2½ x 2 x 2½	3.86	4.06	3.65	2.13	2.48	1.92	PA5130 0202016
3 x 2 x 2	3.42	4.03	3.43	1.49	2.45	1.85	PA5130 0241616
3 x 2½ x 2	3.67	3.89	3.43	1.74	2.16	1.85	PA5130 0241620
3 x 2 x 2½	4.06	4.09	3.90	2.13	2.51	2.17	PA5130 0242016
3 x 2½ x 2½	3.85	4.38	3.94	1.92	2.65	2.20	PA5130 0242020
3 x ¾ x 3	4.13	4.69	4.09	2.20	3.79	2.17	PA5130 0242406
3 x 1 x 3	4.05	4.66	4.02	2.12	3.75	2.09	PA5130 0242408
3 x 1¼ x 3	4.19	4.67	4.06	2.26	3.65	2.13	PA5130 0242410
3 x 1½ x 3	4.25	4.89	4.06	2.32	3.47	2.13	PA5130 0242412
3 x 2 x 3	4.03	4.68	4.06	2.10	3.10	2.13	PA5130 0242416
3 x 2½ x 3	4.12	4.66	4.09	2.19	2.92	2.17	PA5130 0242420
4 x 3 x 2	4.30	5.03	3.90	1.78	3.10	2.32	PA5130 0321624
4 x 3 x 3	4.85	5.50	4.57	2.33	3.57	2.64	PA5130 0322424

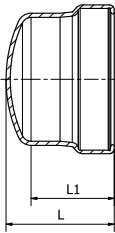
PA5301		End Cap			
	Dimension	L	L1	Product code	
	2 ½	2.22	1.73	PA5301 02000000	
	3	2.54	1.91	PA5301 02400000	
	4	3.17	2.30	PA5301 03200000	

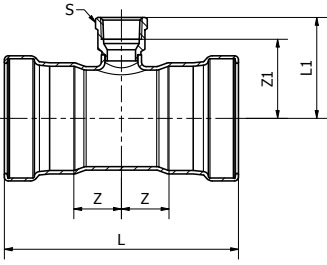
PA5130G		Tee with Female Threaded Branch					
	Dimension	L	L1	Z	Z1	S	Product code
	2 ½ x 2 ½ x ½	5.47	2.42	0.98	1.89	1.02	PA5130G0200420
	2 ½ x 2 ½ x ¾	5.89	2.56	1.20	2.01	1.20	PA5130G0200620
	2 ½ x 2 ½ x 2	6.67	2.80	1.57	2.11	2.56	PA5130G0201620
	3 x 3 x ¾	5.79	2.91	0.98	2.36	1.20	PA5130G0240624
	3 x 3 x 2	6.93	3.15	1.56	2.46	2.56	PA5130G0241624
	4 x 4 x ½	6.81	3.27	1.10	2.74	1.02	PA5130G0320432
	4 x 4 x ¾	6.97	3.41	1.10	2.85	1.20	PA5130G0320632
	4 x 4 x 2	7.95	3.64	1.67	2.95	2.56	PA5130G0321632

*All above measurements are in inches unless stated differently.

>B< Press

>B< Press Gas

>B< Press Solar

>B< Press XL

>B< Press Carbon

>B< Press Inox

>B< Steel

>B< MaxiPro

>B< ACR

K65

<A> Press Inox

>B< Push

>B< Sonic

>B< Oyster

>B< Flex

Triflow Solder Ring

Delcop End Feed

Delbraze

Medical Gas

Valves

Conex Compression

Series 3000

Series 4000

Series 5000

Series 8000

OEM Solutions



IBP Group LLC, 155 Bartram Market Drive, Suite 135, #163 Saint Johns, FL 32259
 (For returns only) IBP Group LLC, 5810 Long Prairie Road, Suite 700, #369 Flower Mound, Texas 75028
 Tel: 904-217-4970 | Fax: 904-460-2603 | Email: SalesUSA@IBPGroup.com | Website: www.conexbanninger.com

Global Headquarters:
 Conex Universal Limited, Global House, 95 Vantage Point, The Pensnett Estate, Kingswinford, West Midlands, DY6 7FT, UNITED KINGDOM.
 Tel: +44 (0) 121 557 2831 | Fax: +44 (0) 121 557 0185 | Email: salesuk@ibpgroup.com | Website: www.conexbanninger.com

The content of this publication is for general information only. It is the user's responsibility to determine suitability of any product, product data and specifications, for the purpose intended and reference should be made to our Technical Department if clarification is required – technical@ibpgroup.com. All products must be installed in accordance with our installation instructions. In the interests of technical development we reserve the right to change specification, design and materials without notice.

Conex Bänninger products are approved by numerous Standards Authorities and Certification Bodies. This is a representation of the full range from Conex Universal Ltd. Patents and trademarks are registered in numerous countries. Details on registered and pending patents protecting our products is available at public patent registers or can be requested from legal@ibpgroup.com. All documents, images and technical data are © of Conex Universal Limited, E&OA.

More information online at: <https://conexbanninger.com/en-us/>