

Threaded Fittings Applications

Installation Instructions

General

Conex Bänninger Series 3000 threaded fittings should be installed by an experienced installer, adhering to the specified installation instructions. All installations **must** be completed in line with local regulations and by-laws governing the installation, and all applicable health and safety practices must be adhered to.

Important thread information

Conex Bänninger Series 3000 threaded fitting are manufactured to **EN 1254-4** with jointing threads to the following specifications (unless stated otherwise):

- **Internal threads** (female): Parallel threads to **ISO 7-1 & EN 10226-1**.
- **External threads** (male): Taper threads to **ISO 7-1 & EN 10226-1**.

Joint information - tightening torque figures

Fitting size (inches)	Torque Nm
1/4"	25 - 27
3/8"	30 - 33
1/2"	45 - 50
3/4"	65 - 70
1"	100 - 110
1 1/4"	150
1 1/2"	200
2"	300

Note: The torque figures above are a guideline. Do not overtighten the joint.

Further Information

Please visit - www.conexbanninger.com or email - technical@ibpgroup.com, for information on:

- Product range.
- Operating parameters & pressures.
- Further technical information.

Applications

Applications	Flow Medium
Drinking water installations EN 806	All types of drinking water as per the drinking ordinance
Hot water-heating EN 12828	Heating water
Cooling and chilled water systems	Water and water-glycol mixtures
Solar thermal systems	Water and water-glycol mixtures
Local and district heating pipelines	Heating or district heated water
Fire-fighting pipelines	Firefighting water
Sprinkler systems	Mains/tank fed water
Rainwater utilisation systems	Rainwater from cisterns
Industrial and processing water	Prepared, softened, partially and partially deionized water with a pH of $6,5 \leq 9,5$
Wastewater lifting units	Wastewater containing faecal material
Natural gas installations EN 1775	Combustion gases
Liquefied petroleum gas installations / technical rules for liquid gas (TRF)	Combustion gases
Systems for distributing technical gases	Gases in various purity classes (no acetylene)
Heating oil supply systems	Heating oil
Hydraulics	Mineral and synthetic oils
Compressed air	Compressed air of all classes according to ISO 8573-1

Note: For parameters outside the above, please contact the Technical Department.

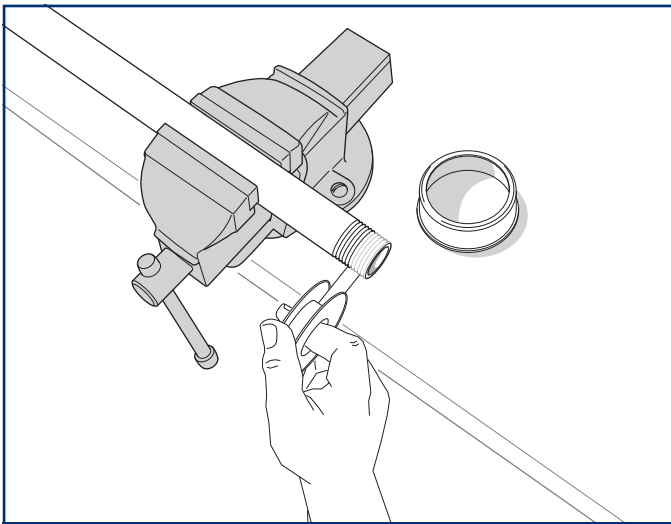

A. Application of PTFE tape

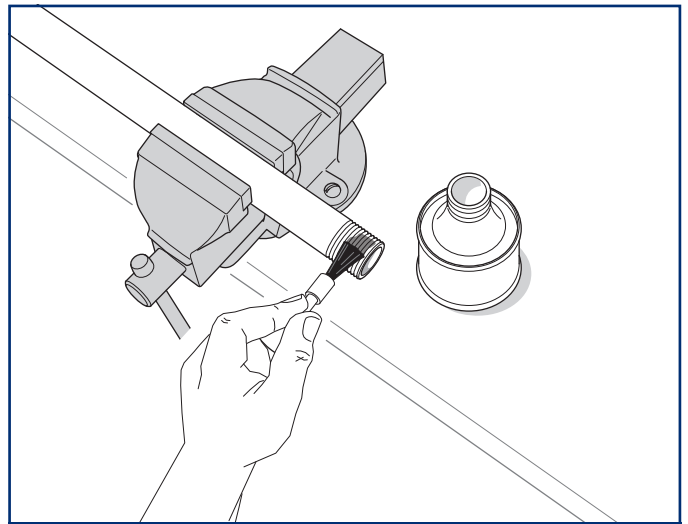

B. Application of liquid sealant

The following instructions apply to Figure A and Figure B

- Check fitting is the correct size before proceeding.
- Apply the *appropriate tape or sealant for the required application on either the threaded tube or fitting.
 - ***Drinking water applications:** WRAS approved Tape or Sealant (please consult manufacturers instructions & specifications).
 - ***Heating systems:** A suitable sealant for the temperatures required (please consult manufacturers instructions & specifications).
 - ***Gas applications:** Either Gas PTFE tape or Gas sealant (please consult manufacturers instructions & specifications).

- **Note:** For **drinking water PTFE tape**, it is advised that at least x5 rounds of tape are applied to the thread. As a minimum, this tape should meet the following standard: **Potable Water PTFE tape to BS 7786.**
- **Note:** For **gas applications PTFE tape**, it is advised that at least x3 rounds of tape are applied to the thread. As a minimum, this tape should meet the following standard: **GAS quality PTFE tape to BS 731-3.**
- IMPORTANT: Always adhere to the sealant manufacturers instructions for curing times of liquid sealants.**

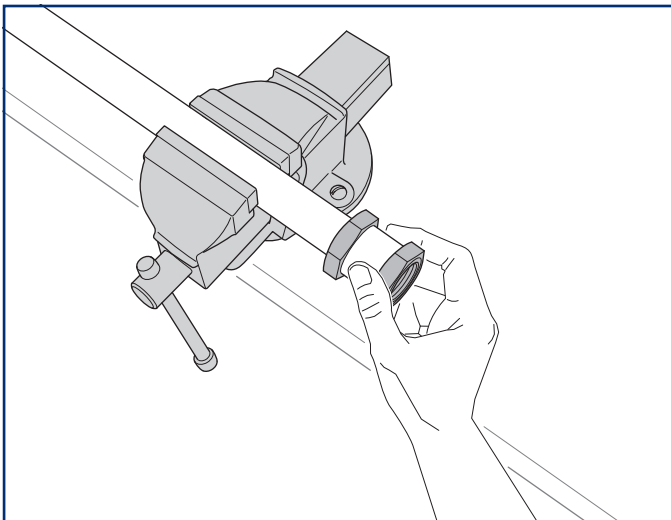

1. Tighten the fitting by hand

- Screw the parts together until hand tight.

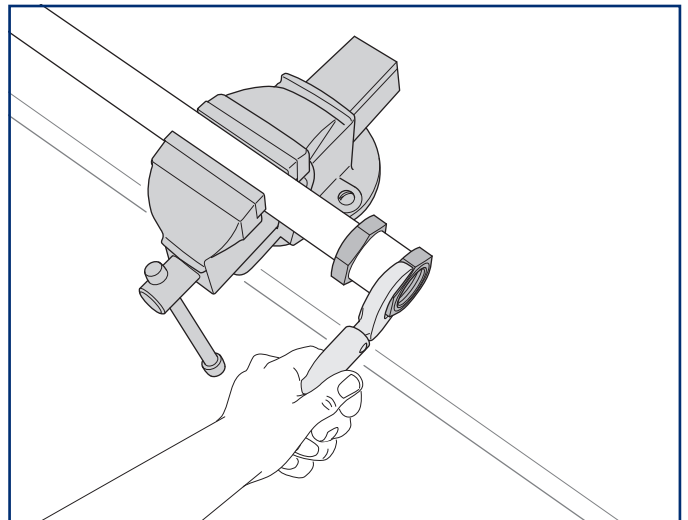

2. Tighten to the stated torque figure

- Using a suitable torque spanner/wrench, tighten the parts together until the stated torque figure for the fitting size is reached (figures are quoted on page 1).
- IMPORTANT: Do not overtighten the joint.**

The content of this publication is for general information only. It is the user's responsibility to determine suitability of any product, product data and specifications, for the purpose intended and reference should be made to our Technical Department if clarification is required – technical@ibpgroup.com. All products must be installed in accordance with our installation instructions. In the interests of technical development we reserve the right to change specification, design and materials without notice.

Conex Bänninger products are approved by numerous Standards Authorities and Certification Bodies. This is a representation of the full range from Conex Universal Ltd. Patents and trademarks are registered in numerous countries. Details on registered and pending patents protecting our products is available at public patent registers or can be requested from legal@ibpgroup.com. All documents, images and technical data are © of Conex Universal Limited. E&OA.