

OEM Solutions

Over 50 Years of Precision - Original Equipment Manufacturing.

Over 50 years serving the market

Conex Bänninger has decades of experience in the OEM sector, supplying bespoke solutions to multiple industries.

We operate in partnership with our customers, listening to their needs and working closely with them at every stage, from the initial design, testing and proving, to the production of an often complex fabrication and pipework.

Our team of qualified, specialist engineers use their technical skills and experience, and our advanced European production facilities, to ensure customer requirements are met in full, complying with the required international industry standards.

Not only that, our solutions save our OEM customers time and money. Installation times are reduced, creating a leaner, more economic, manufacturing production assembly line.





Global Reach

The roots of Conex Bänninger can be traced back more than a century to 1909. Boasting over 110 years of experience, we have gone on to produce more than 22 billion fittings for domestic, commercial, industrial, shipbuilding, air conditioning and refrigeration markets worldwide.

Conex Bänninger today has a worldwide reach, with our innovative products in demand in markets around the globe. Production is centred in Europe at our manufacturing plants in Spain and Poland, where we also have an international distribution centre, with headquarters in the United Kingdom.

Our OEM capabilities are focused on our high tech-facility in Poznan, which is connected to international markets by a network of strategically located offices in different regions, with technical sales managers and other representatives providing additional support.

Customer sectors

Throughout our 50 years of serving the OEM market, we have regularly provided bespoke products and solutions for leading manufacturers in the following sectors:

- Heating/Cooling
- Air handling
- Air conditioning
- Refrigeration
- Petro Chem
- Food & beverage
- Medical
- Renewable technology
- Marine and offshore

We provide OEM solutions for the following:-

- Pre-plumbed cylinders
- Heat interface units
- Heat pumps
- Central heating boilers
- Valves

Our ranges of valves and fittings compliment our end product, whether supplied as part of, or independently to our final solution.

Solutions for heating and hot water appliances



Special bespoke OEM parts, fittings and connections manufactured for the above sectors. These are designed and manufactured in line with our customers requirements on pressures, tolerances and quality assurance compliance.

Bespoke components for the food and beverage or medical sectors



Air conditioning & refrigeration applications

In this sector we provide OEM parts to:

- Air conditioning units
- Packaged refrigeration units
- Fan coil units
- Air handling units

With a varied air-conditioning and refrigeration product range we have the suitability for every occasion.

- K65 - For high pressure applications.
- >B< ACR - A range of copper and copper alloy end feed capillary fittings, specifically designed for the ACR market.

With all ranges being suitable for OEM parts.



Wanda Metropolitan Stadium - K65 supplied for high pressure OEM refrigeration appliances and pipework.

Conex Bänninger is a trusted OEM solutions provider to some of the largest OEM manufacturers in the world.

From boilers and heat pumps, to air conditioning and refrigeration systems, to solar panels and automotive applications, major brands look to us for bespoke components and assemblies that have been specially designed and engineered to meet their exacting requirements.

As a global leader in the manufacture of HVACR fittings, valves and accessories, we are able to complement our OEM capabilities with, manipulation of copper tube, brazing, end forming and T-drilling.



Manufacturing versatility

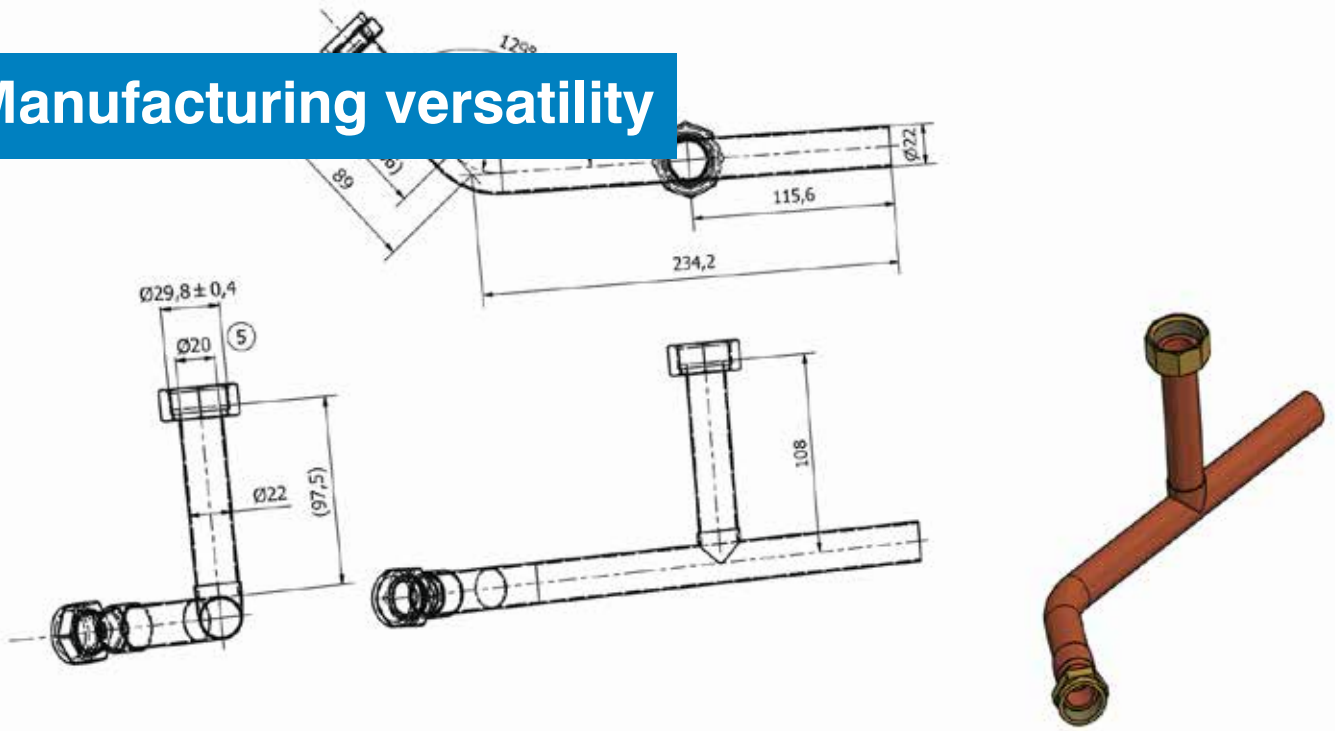

Our specialist OEM division is able to design and produce solutions to suit individual customer specifications, creating precisely-fitting custom-made components and modules that can be integrated into manufacturers' end products.

We work with a wide range of materials, including copper, cupro nickel, bronze (red brass), brass, carbon steel and stainless steel, and multi-layered composite pipe, and we deploy multiple production techniques: soldering, bolting, pressing, clamping and inserting.

Our forming processes include bend, flare, swage, form, T-drill, flow drill, radius dome, flat dome and fabrication, achieved using the latest CNC machinery and other core equipment.

The OEM department also hosts our versatile auto brazing and manual brazing operations, where we have extensive expertise in assembling and brazing fabricated parts up to larger diameters in copper tube.

This manufacturing versatility enables us to meet customers' requirements, whilst also providing confidence in achieving outstanding product repeatability.

Where required, we can also assist in achieving just-in-time, Kanban and other lean manufacturing solutions.

In-house expertise



Our in-house team have a wealth of experience and technical expertise – and are always on hand to support and provide individualised advice. During the crucial product development stage, we work in partnership with our customers to develop precise, custom solutions.

We offer a range of services to match their requirements and build programmes, from in-house design, development of prototypes and pre-production sampling, as well as guidance on environmental legislation and complete plug and play solutions.

Our deep knowledge is combined with a flexible, progressive attitude and passion for problem solving, from prototype to serial production.



Quality assured



All tube is inspected using the state-of-the-art TubeInspect measuring machine. Tube is placed in the chamber as shown and all lengths and angles are measured precisely for conformity and tolerance.

Throughout the whole fabrication process, all fabricated work follows a tight quality control plan.

Every stage, from calibration, cutting size and end shaping, cleaning, drying, brazing to soldering, has point by point tests and controls to ensure compliancy, before moving on to the next stage.

In addition for all pipes designed for refrigeration applications we have our very own hydrogen testing station.

This is where the tube is filled with gas, which is a mixture of 95% nitrogen and 5% hydrogen. Pressures are then raised up to 10 bar.

After filling the tube and stabilizing the pressure we use a special hydrogen detector to check for any potential leakages.

Overall we ensure accuracy and efficiency with everything manufactured in a controlled environment.

“

Our customers have complete peace of mind that we produce to the same high standards that they do with full ISO 9001 accreditation and strict quality control of all our processes.

”

Technical agility

With our technical and design capability along with our engineering knowledge allows us to create bespoke fabrication of components. Our forming processes include bend, flare, T-Drill, flow Drill, radius dome, flat dome and fabrication. We work with a wide range of material sources including copper brass, nickel and bronze, enabling us with the versatility to meet your requirements, no matter how complex.



Bespoke OEM solutions

Customers trust OEM Solutions because they know we can meet their unique needs and provide complete solutions that are tested, validated and supported out of our factory. The innovative creativity of our customers leads to the development of incredible solutions. And no single solution is the same.

Bespoke OEM solutions

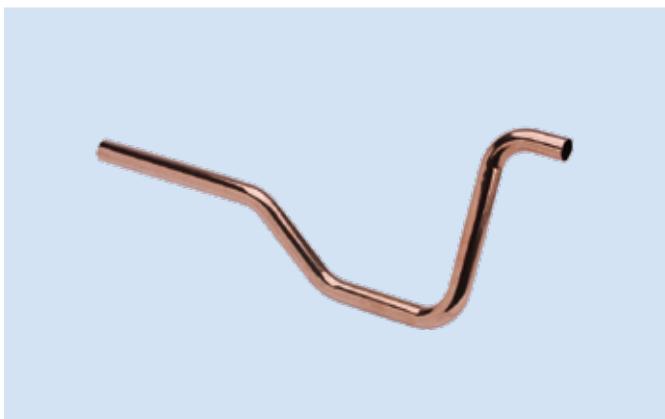
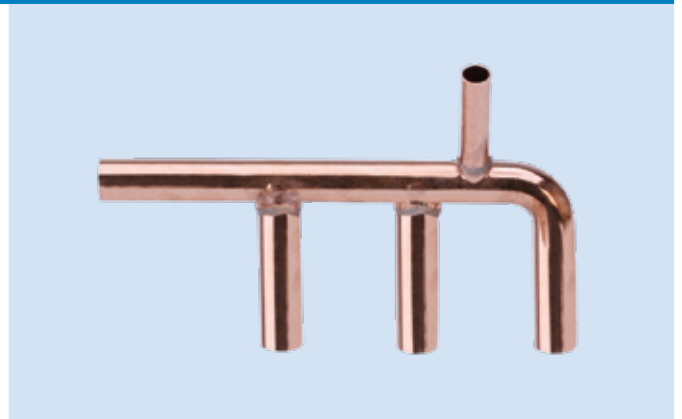



T-Drilling



Complex Solutions



Pipe Manifold



Bespoke Manufacturing



Tube Forming

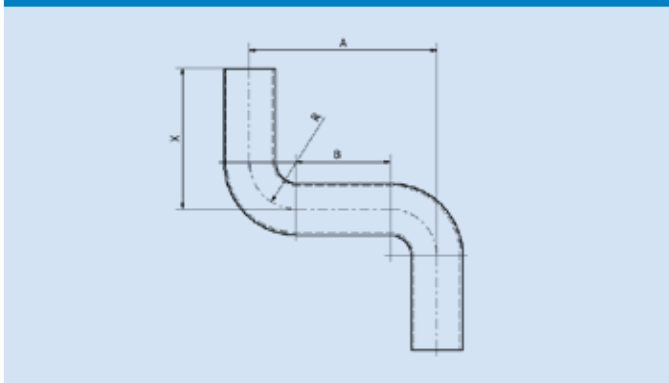

End Forming

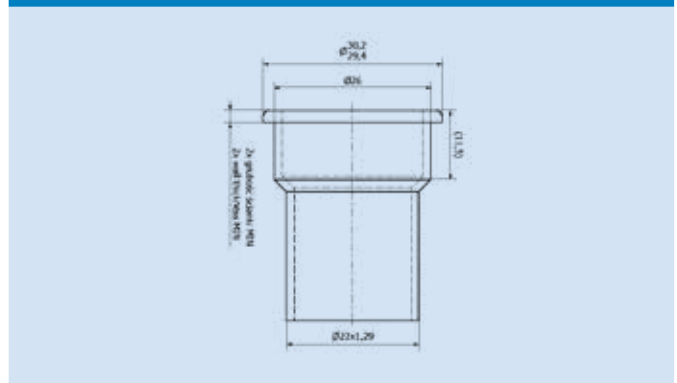

The process

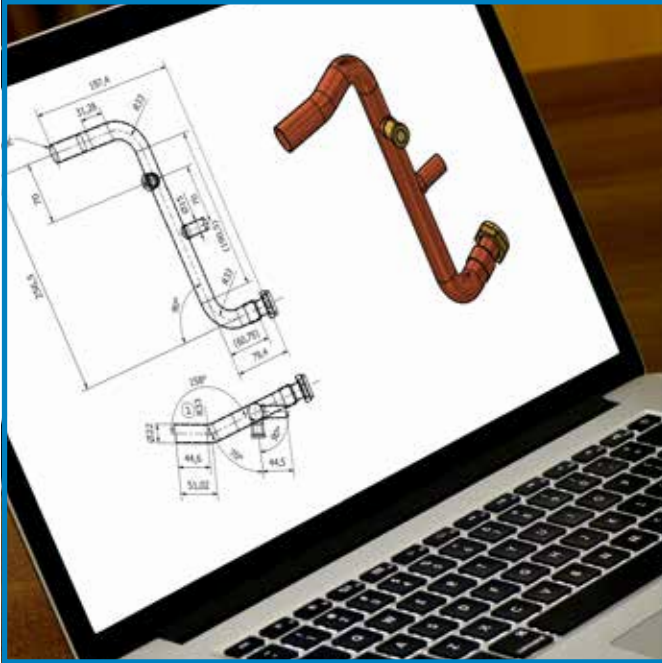

Design

1

Our experienced team use their in-depth knowledge and expertise to create practical solutions that work for each individual project

Manufacture

2

Our investment in the most modern machinery and production methods makes us a leader in OEM solutions



Testing

3

At each and every stage we apply rigorous tests to ensure the finished product meets our customers' requirements and complies with relevant international standards

Distribution

4

Our highly efficient and advanced distribution centre is geared up to successfully manage shipments of all shapes, sizes and quantities, and deliver them via our connected network to markets around the globe

World wide bespoke OEM applications manufactured to suit all customer specifications.



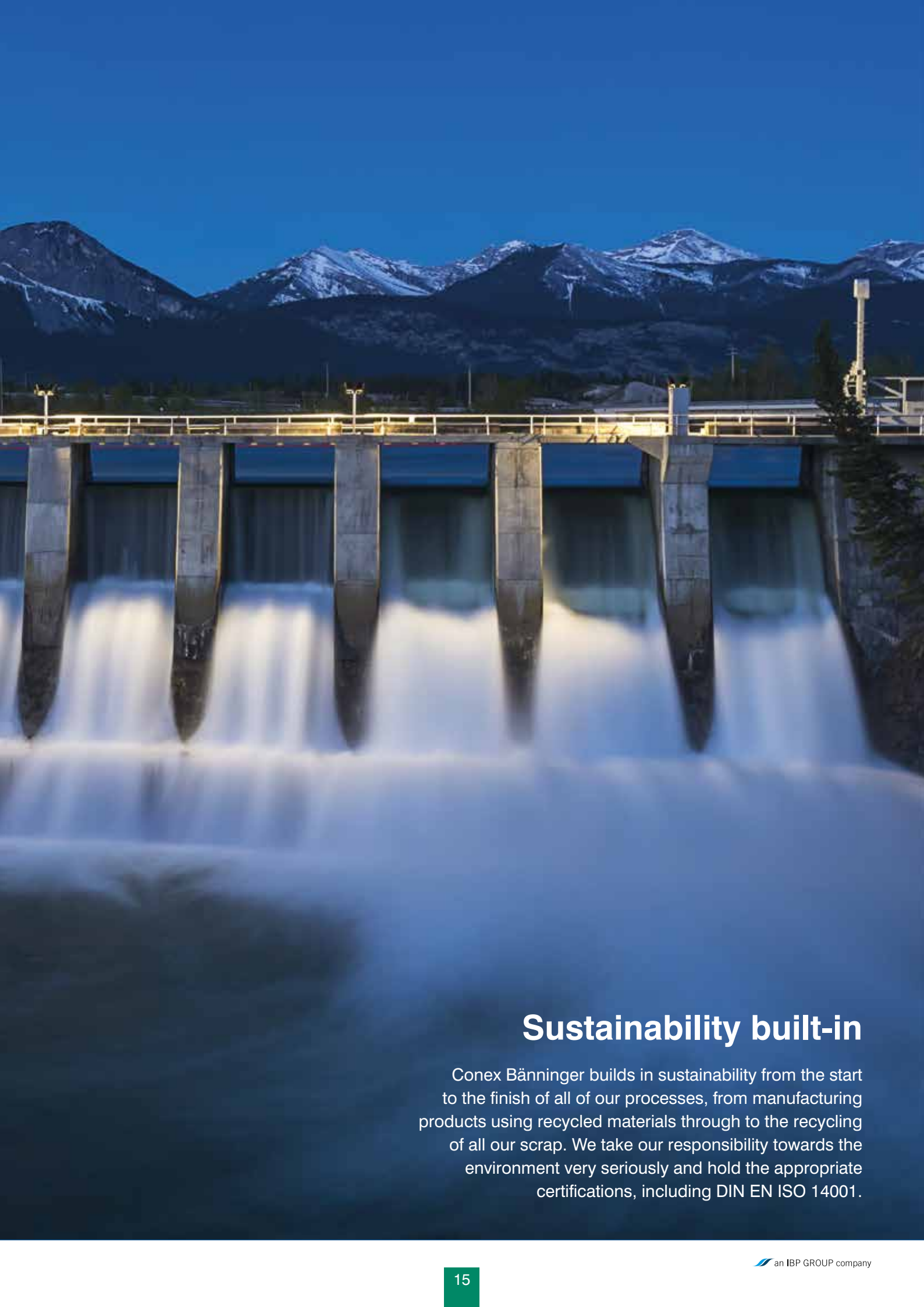

Sustainability built-in

Conex Bänninger builds in sustainability from the start to the finish of all of our processes, from manufacturing products using recycled materials through to the recycling of all our scrap. We take our responsibility towards the environment very seriously and hold the appropriate certifications, including DIN EN ISO 14001.

OEM Solutions

From technical problem solving, superior engineering quality, to time saving and cost reduction, there are many benefits from trusting Conex Bänninger with your OEM options.

Features	Benefits
50 years of OEM solutions	Confidence in ability to deliver
Supply some of the largest manufacturers	Trusted partner
Advanced production facilities	Lean manufacturing, speed of delivery
Technical agility	Bespoke manufacturing capability
Comprehensive Industry Standards	Quality assurance
Recycling & less waste	100% recyclable

Comprehensive range of fittings & valves available

Conex Bänninger has a long history of pioneering new products and we offer a complete range of fittings and valves for use with copper, brass, bronze and inox.



>B< Press



>B< MaxiPro



End Feed



Push-fit



K65



Threaded



Conex Compression



Valves

Components

The complexity and variety of OEM applications requires an extensive product range to meet those specific needs. We manufacture all types of components and valves for bespoke OEM applications including the following:



Pipe overflow assembly



Base pipe manifold



Pipe plate heat exchanger outlet



Pump valve ball type



Braided flexible connection



Thermostatic mixing valve



Air vent



Air separator



Safety valve

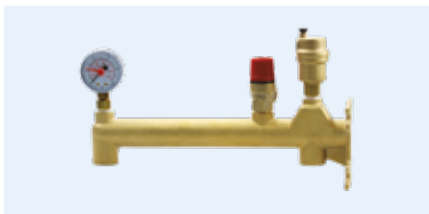

Boiler component



Safety relief valve



Pressure reducing valve



Manifold



Ball valve



Ball valve with w/drain



Female swivel fitting



Boiler valve



Static balancing valve

Continual innovation

As well as supplying high quality standard fittings, Conex Bänninger is constantly developing new ranges, such as >B< Press and >B< Push, for hot and cold water and heating applications, and >B< MaxiPro for ACR, all of which offer flame free installation solutions.

These are quick and easy to install, saving on labour costs and offer a secure, permanent, leak proof joint.



International contacts

United Kingdom and Ireland

Tel: +44 (0)121 557 2831

Email: salesuk@ibpgroup.com

Global House, 95 Vantage Point

The Pensnett Estate, Kingswinford, West Midlands DY6 7FT

UK

North Africa

Tel: +33 967 579 554

Email: sales.northafrica@ibpgroup.com

45 Rue Boissiere, Paris

75016

France

South Africa

Tel: +44 (0)121 557 2831

Email: sales.southafrica@ibpgroup.com

Global House, 95 Vantage Point, The Pensnett Estate,

Kingswinford, West Midlands DY6 7FT

UK

China

Tel: 0086 4001085686

Email: nbibp@ibpchina.com

Technical Service Center

Floor 43, Building A, International Trade Center, Ningbo Chamber of Commerce

No.558 of Taikangzhong Road, Yinzhou District, Ningbo, China 315100

France

Tel: +33 967 579 554

Email: sales.france@ibpgroup.com

45 Rue Boissiere, Paris,

75016

France

Germany and Central Europe

Tel: +49 (0) 6403 / 77 85 – 0

Email: customerservicede@ibpgroup.com

Theodor-Heuss-Straße 18

35440 Linden,

Germany

International (Rest of world)

Tel: +44 (0)121 521 2921

Email: international@ibpgroup.com

Global House, 95 Vantage Point

The Pensnett Estate, Kingswinford, West Midlands DY6 7FT

UK

Italy

Tel: +39 0521 299711

Email: tecnico.ibpbanneritalia@ibpgroup.com

Piazza Meccio Ruini 9A

43126 Parma

Italy

Middle East

Tel: +971 (0) 4580 7003

Email: gulf@ibpgroup.com

Office 505, 1 Lake Plaza

Jumeriah Lake Towers

Dubai UAE

Poland and Eastern Europe

Tel: +48 61 660 96 40

Mob: +48 603 421 244

Email: customerservicePO@ibpgroup.com

ul. Stanisława

Zwierzchowskiego 29

61-249

Poznan, Poland

ul. Za Motelem 2A

Tarnowo Podgorne

62-080

Sady, Poland

Spain and Portugal

Spain: **Tel:** +34 957 469 629

Email: Sales.spain@ibpgroup.com

Portugal: **Tel:** +351 919 413 508

Email: salesportugal@ibpgroup.com

Poligono Industrial

Quintos Aeropuerto

14005

Spain

USA

Tel: 904-217-4970

Email: salesUSA@ibpgroup.com

Suite 400, 24 Cathedral Place

St Augustine, Florida

32084

Conex | Bänninger

The content of this publication is for general information only. It is the user's responsibility to determine suitability of any product, product data and specifications, for the purpose intended and reference should be made to our Technical Department if clarification is required – technical@ibpgroup.com. All products must be installed in accordance with our installation instructions. In the interests of technical development we reserve the right to change specification, design and materials without notice.

Conex Bänninger products are approved by numerous Standards Authorities and Certification Bodies. This is a representation of the full range from Conex Universal Ltd. Patents and trademarks are registered in numerous countries. Details on registered and pending patents protecting our products is available at public patent registers or can be requested from legal@ibpgroup.com. All documents, images and technical data are © of Conex Universal Limited. E&OA.

More information online at: www.conexbanninger.com