

<A> Press Inox



<A> Press Inox Technical Brochure - 304
15 to 108mm



Contents

1. General	1
1.1 Quality and certification	
1.2 Features and benefits	
1.3 Materials and threads	
1.4 Storage and handling	
1.5 Black EPDM sealing elements	
1.6 Unpressed joint indicator	
1.7 Cold bending of stainless steel tubes	
1.8 System testing	
1.9 Electrical continuity	
1.10 Recommended water velocities	
1.11 COSHH (Control of substances hazardous to health)	
1.12 Tube compatibility	
1.13 Product marking	
2. Product Suitability & Applications.....	3
3. Thermal Expansion	4
3.1 Effects of expansion	
3.2 Expansion devices	
4. Corrosion Resistance, Frost / Heat Protection	6
4.1 Internal corrosion	
4.2 Disinfection	
4.3 External corrosion	
4.4 Thermal insulation	
4.5 Protection against frost and heat gain	
4.6 Connecting to other materials	
5. Pressure Testing	6
6. Compatible Press Tools	7
6.1 Tool chart	
7. Loss Coefficients	8
8. Installation Requirements	10
8.1 Space required for the pressing process	
8.2 Insertion depth and minimum distances between pressings	
8.3 Minimum distance for press fittings from an existing brazed joint	
8.4 Minimum welding or brazing distance to an existing pressed fitting	
8.5 <A> Press INOX tube compatibility table	
9. Tube Preparation	12
10. Fitting Installation Instructions.....	13
11. The Range.....	14
12. Product Guarantee.....	26

1. General

<A> Press Inox M profile is a flame-free fitting, manufactured using high quality stainless steel 1.4301 (AISI 304), offers a high resistance to corrosion and is suitable for non-drinking water applications.

1.1 Quality and certification

Conex Bänninger has 110 years of experience in manufacturing innovative products and operates an accredited Quality Management System to EN ISO 9001.

1.2 Features and benefits

- Suitable for hot and cold water installations, local and district heating, rainwater harvesting, oil-free compressed air and vacuum (for additional applications please refer to section 2).
- Easy to install, saving on labour time.
- Permanent, flame-free connection – no brazing or soldering consumables or hot works permit required.
- Unpressed joint indicator assists identification of unpressed joints.
- Maximum continuous operating temperature 110°C.
- Manufactured using high quality materials, including an EPDM O-ring, that is to applicable standards.
- Suitable for in-built water installations.
- Tested and approved by national and international standard authorities.
- Full product guarantee, for full terms and conditions please see section 13.
- Available in sizes 15 to 108mm.
- Suitable for use with stainless steel tubes to EN 103 series 1 and 2. See tube compatibility table in section 8.5.
- Compatible with commonly available press tools (see section 7).

1.3 Materials and threads

<A> Press Inox fittings are available in Material grade 1.4301 (AISI 304) and is suitable for non drinking water applications.

<A> Press Inox tubes are available in material 1.4301 (AISI 304). The tubes correspond in properties and dimensions with the requirements of EN 10312 in both wall thicknesses, Series 1 and 2.

Threaded connections

<A> Press Inox fittings are available with male and female threaded connections to the following standards:

- Jointing threads are to ISO 7-1 and EN10226-1. Female are parallel and male are taper.
- Fastening threads are to ISO 228-1 parallel.



1.4 Storage and handling

Store in a cool and dry place to protect the fittings from contamination, damage and dirt. Keep out of direct sunlight. Fittings should be left in their packaging to preserve the lubrication on the O-rings prior to installation.

1.5 Black EPDM sealing elements

<A> Press Inox EPDM O-rings are peroxide-cured rubber seals with high elasticity, excellent cold and heat performance.

Please refer to section 2 for the fitting operating parameters for the different applications.

1.6 Unpressed joint indicator

<A> Press Inox benefits from patented 'unpressed joint indicator' O-ring technology (15 to 54mm) which indicates if a joint has not been pressed. The O-ring contains two in-built water pathways that in the unpressed condition allows water to pass through and create a noticeable leak when the system is tested at low pressure (0.1 to 6.0 bar). Any unpressed joints can be pressed without draining down.



1.7 Cold bending of stainless steel tubes

Stainless steel tubes up to 28mm, comply with EN 10312 Series 1 & 2. Tubes can be bent cold with suitable bending equipment, with a minimum bend radius of 3.5 times the tube diameter.

1.8 System testing

Pressure testing should be carried out to the appropriate standard (e.g. EN 806 specifies 1.1 x maximum design pressure) or to the satisfaction of the supervising engineer with a maximum test pressure of 1.5 times the operating pressure. See section 5 for more information on pressure testing.

1.9 Electrical continuity

<A> Press Inox fittings maintain earth continuity without the need for additional continuity straps.

1.10 Recommended water velocities

Please note the maximum allowances for water velocities are per the relevant national standards and codes, which includes EN 806 part 2 and part 3.

1.11 COSHH

(Control of substances hazardous to health)

It is the responsibility of the end user to ensure that adequate protection is available where required and the necessary information regarding possible health and safety regulations is adhered to. Stainless steel fitting is considered non-hazardous under normal circumstances.

1.12 Tube compatibility

<A> Press Inox fittings are suitable for use with stainless steel tubes manufactured in accordance with EN 10312 Series 1 and 2. Please refer to section 8.5 for the full tube compatibility table.

1.13 Product marking

- <A> Press Inox 304 fittings are marked on the body '304'

2. Product Suitability & Applications

<A> Press Inox 304 is suitable for use in a variety of applications with the operating parameters outlined in table 1.

Installations must be planned and operated in accordance with local regulations, codes of practice and by laws and standards governing the installation e.g. EN 12828: Heating systems in buildings. Design for water-based heating systems.

For information on corrosion protection please see section 5.

Table 1

Application	Flow medium	Pressure bar	Temp °C	M 304
Hot water heaters EN 12828	Heating water	16	110 max	✓
Local and district heating tubes	Heating and district heating water	16	110 max	✓
Thermal solar systems with operating temperatures ≤ 110°C EN 12975 /12976	Water and water-glycol mixtures. Mixing ratio max 50/50%.	6	-35 to +110	✓
			180 ≤ 30 h/a*	
			200 ≤ 10 h/a*	
Water based air conditioning systems	Water and water-glycol mixtures. Mixing ratio max 50/50%.	6	-10 min	✓
Rainwater harvesting systems	Rainwater from cisterns.	10	25	✓
Oil-free compressed air	Compressed air classes 1 - 3 in accordance with ISO 8573-1	10	≤60	✓
Vacuum lines for non-medical purposes	N/A	-0.8	Ambient	✓

3

Maximum acceptable chloride level is 200 ppm for 304 material in supply and waste water systems.

* h/a – Hours per annum

** In the event of deviating parameters, please contact the technical department, technical@ibpgroup.com.

For applications outside those stated in the table above, please contact the technical department: technical@ibpgroup.com.

<A> Press 304 installations must be planned and operated in accordance with local regulations, codes of practice, by laws and standards governing the installation.

3. Thermal Expansion

3.1 Effects of expansion

Using the general equation for change in length (linear expansion) which is:

$$\Delta L = L \times \Delta t \times \alpha$$

Where:

ΔL = change in length in mm

L = length in m

Δt = change in temperature °C

α = coefficient of linear expansion.

For example, a 10m length of 304 stainless steel tube, irrespective of its size, wall thickness or temper, will increase in length by 10.38mm with a temperature rise of 60 where the coefficient of linear expansion for 304 stainless steel = 0.0173 i.e. $10.38 = 10 \times 60 \times 0.0173$.

Tubes installed on hot water services must be free to accommodate this expansion; otherwise stresses will build up in the pipework that may lead to joints being pulled apart and/or tubes fracturing. Clearly the magnitude and frequency of such changes in length will determine the life of the joint or failure of the tube.

Table 3 shows the amount of tube expansion for a given temperature rise. In the case of tube in domestic hot water and heating installations the limited size of rooms and hence straight tube runs, together with the many bends and offsets that normally occur, will result in thermal movement being accommodated automatically. However, where long straight tube runs, exceeding 10m, are encountered, allowance for expansion should be made.

A quick, economic and effective way of accommodating thermal expansion is to simply incorporate the horseshoe or compensating bend to the system design.

3.2 Expansion devices

Where stainless steel tubes pass through walls, floors and ceilings, they should be able to move as a result of expansion and contraction. This can be arranged by passing the tube through a sleeve or length of larger diameter tube fixed through the whole thickness of the wall, floor or ceiling, or by means of flexible joints on either side of the wall.

Short stubs to and from radiators, connected to relatively long straight runs should also be avoided. This can usually be achieved by introducing an expansion loop, thereby increasing the length of pipework fixed between the flow/return legs and the radiator connection. However, expansion accommodation techniques such as the use of loops and horseshoes may not be sufficient to accommodate large expansions and in such cases the use of the bellow type couplers may be necessary.

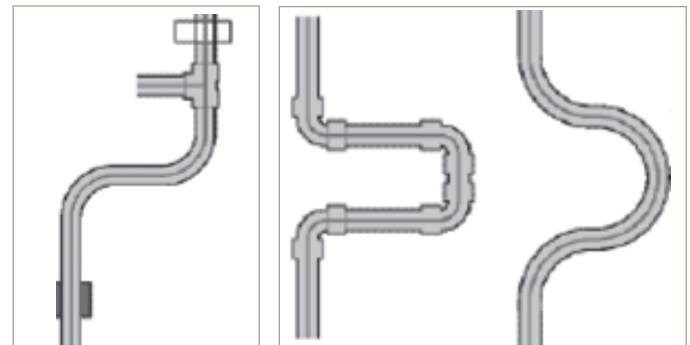

By change of direction

Horseshoe or compensating bend



The table below shows the increase in length due to thermal expansion as a function of change in temperature Δt and the length of the tube, irrespective of diameter, temper or wall thickness.

Table 2

Thermal Expansion - Stainless Steel 304 - Coefficient of Expansion = 0.0173								
Tube length m	Change in length mm with temperature difference Δt °C							
	$\Delta t=30^\circ$	$\Delta t=40^\circ$	$\Delta t=50^\circ$	$\Delta t=60^\circ$	$\Delta t=70^\circ$	$\Delta t=80^\circ$	$\Delta t=90^\circ$	$\Delta t=100^\circ$
1	0.519	0.692	0.865	1.038	1.211	1.384	1.557	1.73
2	1.038	1.384	1.73	2.076	2.422	2.768	3.114	3.46
3	1.557	2.076	2.595	3.114	3.633	4.152	4.671	5.19
4	2.076	2.768	3.46	4.152	4.844	5.536	6.228	6.92
5	2.595	3.46	4.325	5.19	6.055	6.92	7.785	8.65
10	5.19	6.92	8.65	10.38	12.11	13.84	15.57	17.3
15	7.785	10.38	12.975	15.57	18.165	20.76	23.355	25.95
20	10.38	13.84	17.3	20.76	24.22	27.68	31.14	34.6
25	12.975	17.3	21.625	25.95	30.275	34.6	38.925	43.25



4. Corrosion Resistance, Frost / Heat Protection

4.1 Internal corrosion

The term stainless comes from the steels ability to form a thin but dense protective film, known as the passive layer, which minimises the effects of corrosion and provides high levels of hygiene, durability and water quality.

The passive layer is formed when the chromium content of the material reacts with oxygen, resulting in the compound chromium oxide.

Chloride ions have the ability under certain conditions to penetrate the passive layer and cause localised corrosion.

Stainless steel 304 is suitable for waters containing less than 200ppm chloride ions at ambient temperature.

It has also been proved that the risk of crevice and pitting corrosion increases with temperature. It is therefore important that local chloride levels are taken into consideration and risks are minimised with the use of a suitable corrosion inhibitor for heating and cooling systems.

Please refer to manufacturers instructions regarding the use of inhibitors in stainless steel systems.

For further information on the protection of metallic materials against corrosion please refer to EN 12502 and EN 14868.

4.2 Disinfection

If there is a requirement to disinfect the system, the use of hydrogen peroxide (H₂O₂) is permitted provided the lines are comprehensively flushed with fresh water.

4.3 External corrosion

In the event that a stainless steel system is exposed to corrosive environments external to the system, such as chloride from cladding materials or coastal/offshore sites, it is recommended that prior to the application of thermal insulation, a suitable protective paint or appropriate thickness aluminium foil wrap or thermal spray is applied.

Any corrosion barriers should be applied in accordance with BS 5970 - Code of practice for thermal insulation of pipework and equipment.

4.4 Thermal insulation

The thermal insulations of tubes should be implemented in accordance with national codes and standard including BS 5970.

4.5 Protection against frost and heat gain

Regulations require that all water services (except warning or overflow pipes) shall be protected from freezing

temperatures and heat gain. This is best achieved by protecting the system by use of a suitable thickness of insulation or in the case of particular situations such as unheated roof spaces that require special care, a self-regulating trace heating tape.

If a frost protection inhibitor is to remain in the pipelines permanently, at least one concentration test must be carried out annually. All chemical additions must be agreed before use to rule out negative interactions with materials and sealing elements (O-rings).

4.6 Connecting to other materials

Stainless steel, copper and copper alloys can be combined in a single system with no restriction of flow direction.

However in order to minimise the likelihood of galvanic corrosion, a direct connection should not be made in systems where the use of corrosion inhibitors is not possible, and a dielectric union or copper alloy spacer of at least 50mm should be used for this connection.

For further information on galvanic corrosion, please refer to EN14868 for closed water circulation systems and EN 12502-4 for guidance specific to stainless steel systems.

5. Pressure Testing

It is preferable that testing a system containing <A> Press Inox fittings is initially carried out pneumatically with oil-free compressed air or inert gas (eg nitrogen).

This is particularly important where systems are to remain idle for extended periods of time, and if tested hydrostatically and not properly drained or flushed (See section 5.1), there is the potential for bacteria growth and or corrosion. Pneumatic testing shall be carried out to a maximum of 3 bar and the pressure shall be increased slowly and incrementally.

A hydrostatic test shall only be carried out immediately prior to commissioning the installation. The system shall be filled with clean drinking water against an open high point valve allowing all trapped air to be removed from the network. Once free of trapped air, the high-level valve should be closed and the system topped up, at that stage testing should be completed between 1-2 bar to ensure any un-pressed joints are identified. The recommended system test pressure should be in accordance with the requirements of EN 806 part 4 (1.1 x maximum design pressure or to the satisfaction of the supervising engineer with a maximum test pressure of 1.5 times the operating pressure). Full test pressure should be maintained for a minimum of 30 minutes with without any sign of pressure drop. A full inspection should then be carried out to

identify any leaks.

During hydrostatic or pneumatic testing, any joints identified as unpressed and are showing signs of leakage should be pressed upon the return to atmospheric pressure, however it is essential the tube is fully inserted to the tube stop prior to pressing.

All joints shall remain uncovered and visible when pressure testing systems containing <A> Press

Inox fittings.

Pressure testing should be carried out in accordance with national regulations and appropriate specifications drawn up and a risk assessment must be completed prior to testing.

6. Compatible Press Tools

6.1 Tool chart

Table 3

15 to 35mm Compact 19 kN machines						
Manufacturer	Press machine	Press jaws	Size range (mm)	Profile	EN 10312 Series 1	EN 10312 Series 2
Rems	Mini Press ACC	Rems - Mini	15 to 35	M	✓	✓
Klauke	MAP219/MAP2L19	Klauke – SBMX	15 to 28	M	x	✓
Novopress	ACO102/ACO103	NovoPress - Press jaw M15 to M35	15 to 35	M	✓	✓
Geberit Mapress	ACO102/ACO103	Geberit - Press jaws [1 series] M15 to M35 (Black colour)	15 to 35	M	✓	✓
Pegler XPress	ACO102/ACO103	Pegler SB211 PB1 series	15 to 35	M	✓	✓

Table 4

15 to 54mm Standard 32 kN machines						
Manufacturer	Press machine	Press jaws	Size range (mm)	Profile	EN 10312 Series 1	EN 10312 Series 2
Rems	Power-Press/ Akku-Press	Rems - Standard	15 to 54	M	✓	✓
Klauke	UAP2/UAP3L/UAP332	Klauke - Standard SB	15 to 54	M	x	✓
Novopress	ECO202/ACO202	Novopress - Press jaws M15 to M35	15 to 35	M	✓	✓
	ECO203/ACO203	Novopress - Press Collars - M42, M54 plus ZB203 Adaptor	42 to 54	M	✓	✓
	ACO202XI/ACO203XL	Novopress - Press Collars - M42, M54 plus ZB203 Adaptor	42 to 54	M	✓	✓
Geberit Mapress	ECO202/ACO202	Geberit - Press jaws [2 series] M15 to	15 to 35	M	✓	✓
	ECO203/ACO203	M35 (Black colour)	15 to 35	M	✓	✓
	ACO202XI/ACO203XL	Geberit - Press Collars - M42, M54 plus ZB203A Adaptor	42 to 54 42 to 54	M M	✓ ✓	✓ ✓
Pegler Xpress	ECO202/ACO202	Pegler S227 ECOTEC series	15 to 35	M	✓	✓
	ECO203/ACO203	Press Jaws	15 to 35	M	✓	✓
	ACO202XI/ACO203XL	Pegler S228 series Press Collars plus ZB203 Adaptor	42 to 54 42 to 54	M M	✓ ✓	✓ ✓

Table 5









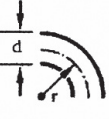

76 to 108mm Standard 32 kN machines			
Manufacturer	Press machine	Press sling/Chain/Collar/Ring	Jaw profile
Novopress	ACO202XL/203XL	Novopress - Collars + ZB231 + ZB322 adaptor	M
Klauke	UAP4/UAP4L/UAP432	Klauke - Chains + SBKQC adaptor	KSP3

For full machine/tool compatibility please refer to the website - www.conexbanninger.com

<A> Press Inox

7. Loss Coefficients (Zeta Values)

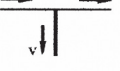
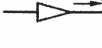
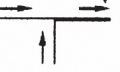
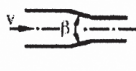
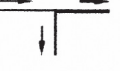
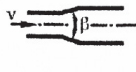
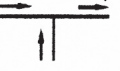
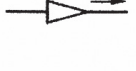
Table 6

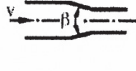
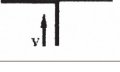
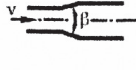
Symbol	Designation	ζ	Application		Symbol	Designation	ζ	Application	
			DW	H				DW	H
	Angle or elbow reference value in accordance with DIN 1988 T3	0,70	X	X		Distributor outlet	0,5	X	X
	Angle 90° r/d (r/d = 1,2 = 1,0 with fittings complying with DIN EN 1254) = 2,0 = 3,0	1,0 0,35 0,20 0,15	X X X X	X X X X		Collective inlet	1,0	X	X
	Angle $\beta = 90^\circ$ $= 60^\circ$ $= 45^\circ$	1,3 0,8 0,4	X X X	X X X		Reservoir outlet	0,5	X	
	Crossover	0,5	X	X		Inlet	1,0	X	X
	Branch, square flow separation	1,3	X	X		Reducer	0,4	X	X
	Flow merging	0,9	X	X		Constriction β - constant = 30° = 45° = 60°	0,02 0,04 0,07	X X X	X X X
	Clearance at flow merging	0,3	X	X		Expansion β - constant = 10° = 20° = 30° = 40°	0,10 0,15 0,20 0,20	X X X X	X X X X
	Clearance at flow merging	0,6	X	X		Expansion bends	1,0	X	X
	Counter-flow at flow merging	3,0	X	X		Compensator	2,0	X	X
	Counter-flow at flow separation	1,5	X	X		Compensator	2,0	X	X

Symbol	Designation	ζ	Application		Symbol	Designation	ζ	Application			
			DW	H				DW	H		
	Branch, curved flow separation	0,9	X	X		Shut-off valve Straight seat valve DN15 DN20 DN25 DN32 DN40 to DN100	10,0 8,5 7,0 6,0 5,0	X X X X X	X X X X X		
	Flow merging	0,4	X	X			Angle seat valve DN 15 DN20 DN 25 to DN50 DN65	3,5 2,5 2,0 0,7	X X X X	X X X X	
	Clearance at flow separation	0,3	X	X				Return flow inhibitor DN 15 to DN 20 DN 25 to DN 40 DN 50 DN 65 to DN 100	7,7 4,3 3,8 2,5	X X X X	
	Clearance a flow merging	0,2	X	X					Control valve with return flow inhibitor DN 20 DN 25 to DN 50	6,0 5,0	X X
	Angle valves DN 10 DN 15 DN 20 to DN 50 DN 65 to DN 100	7,0 4,0 2,0 3,5 4,0	X X X X X	X X X X X					Valve tapping sleeve DN 25 to DN 80	5,0	X
	Diaphragm valves DN 15 DN 20 DN 25 to DN 32 DN 40 to DN 100	10,0 8,5 7,0 6,0 5,0	X X X X X	X X X X X					Boiler	2,5	
	Shutter valves Piston valves Ball valves DN 10 to DN 15 DN 20 to DN 25 DN 32 to DN 150	1,0 0,5 0,3	X X X	X X X					Heating radiator	2,5	
	Radiator valves	4,0		X					Panel radiator	3,0	
	Control valve	2,0		X							
	Pressure regulator fully open	30,0		X							

<A> Press Inox

8. Installation Requirements

8.1 Space required for the pressing process

The following minimum clearances are required from structural components to allow operation of tool for press fitting.

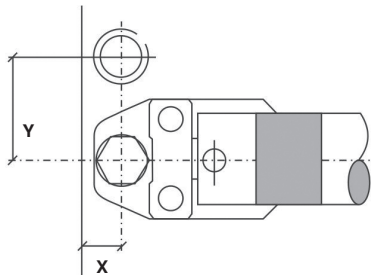

Table 7

Space required for the pressing process between fittings and wall.		
External tube	X	Y
Size mm	mm	mm
15	26	53
22	26	56
28	33	69
35	33	73
42	75	115
54	85	120
76.1	115	165
88.9	125	185
108	135	200

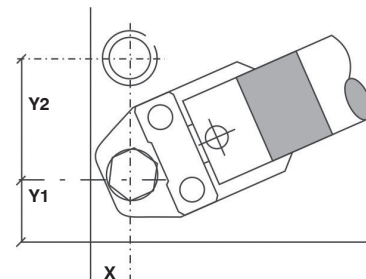

Table 8

Space required for the pressing process between fittings and wall corner.			
External tube	X	Y1	Y2
Size mm	mm	mm	mm
15	31	45	73
22	31	45	76
28	38	55	80
35	38	55	85
42	75	75	115
54	85	85	140
76.1	115	115	165
88.9	125	125	185
108	135	135	200

8.2 Insertion depth and minimum distances between pressings

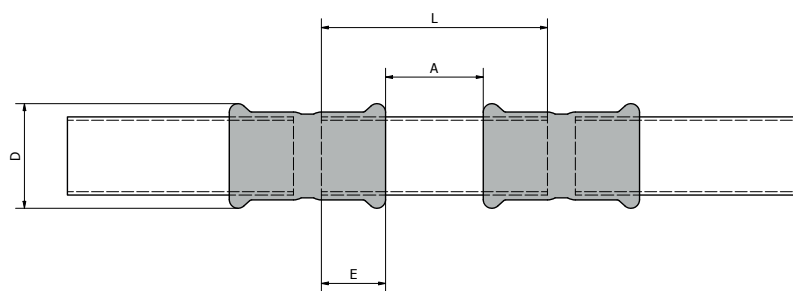

Table 9

Insertion depth and minimum distance between pressings				
Size	External - Ø pressing bead	Minimum distance	Minimum tube length	Insertion depth
mm	D - mm	A - mm	L - mm	E - mm
15	22	10	50	20
18	25	10	55	20
22	23	20	62	21
28	35.5	20	66	23
35	42.5	25	77	26
42	51	30	90	30
54	62.7	35	105	35
76.1	81	40	142	52
88.9	94	50	142	52
108	114	50	170	60

8.3 Minimum distance for press fittings from an existing welded or brazed joint.

To ensure proper sealing of both the welded/brazed and <A> Press Inox fitting, the following minimum distances must be maintained between the two fittings. Please see Table 10 for further information.

Table 10

Minimum distance from a welded joint	
Tube size	mm
15	5
22	5
28	5
35	10
42	15
54	20
76.1	40
88.9	50
108	50

8.4 Minimum welding or brazing distance to an existing pressed fitting

Caution: welding or brazing near <A> Press Inox joints should be avoided as this may cause the seal to degrade due to heat transfer. Table 11 states the minimum distance away from the press joint which is acceptable to weld or braze. If this distance cannot be maintained then adequate precautions must be taken such as fabricating the welded or brazed section prior to assembly with the press fittings, wrapping in a wet rag or applying a hot block to prevent heat transfer to the press fitting during welding/brazing.

Table 11

Minimum distance welding	
Tube size	mm
15	450
22	600
28	700
35	900
42	1200
54	1500
76.1	2000
88.9	2000
108	2000

8.5 <A> Press Inox tube compatibility table

The dimensions of stainless steel tube, to be used with <A> Press Inox need to be to standard EN 10312 Series 1 or Series 2.

Table 12

Tube O/D	Tube wall thickness (mm)	
	Wall thickness (series 1)	Wall thickness (series 2)
15	0.7	1.0
18	0.7	1.0
22	0.7	1.2
28	0.8	1.2
35	1.0	1.5
42	1.1	1.5
54	1.2	1.5
76.1	1.5	2.0
88.9	N/A	2.0
108	N/A	2.0



9. Tube Preparation

To ensure a secure and permanent joint the tube must be correctly prepared prior to installation. Incorrect tube preparation can result in damaging the O-ring and causing the fittings to leak.

Note: Avoid grinding wheels, fast cutting saw and hacksaws as they are not suitable for cutting tube. If the tube ends become distorted, remove the damaged section by using the appropriate cutting method.

When preparing tube ensure that the tube is correctly supported and eye protection is worn. If using

power tools, great care must be taken. Refer to the manufacturers instructions before use.

Safety note: When using press tools, care must be taken to ensure hands are kept away from the jaw during the pressing process. Always wear ear and eye protection.

Sizes 15 - 108mm

For instructions on how to cut the tube please refer to section 11.

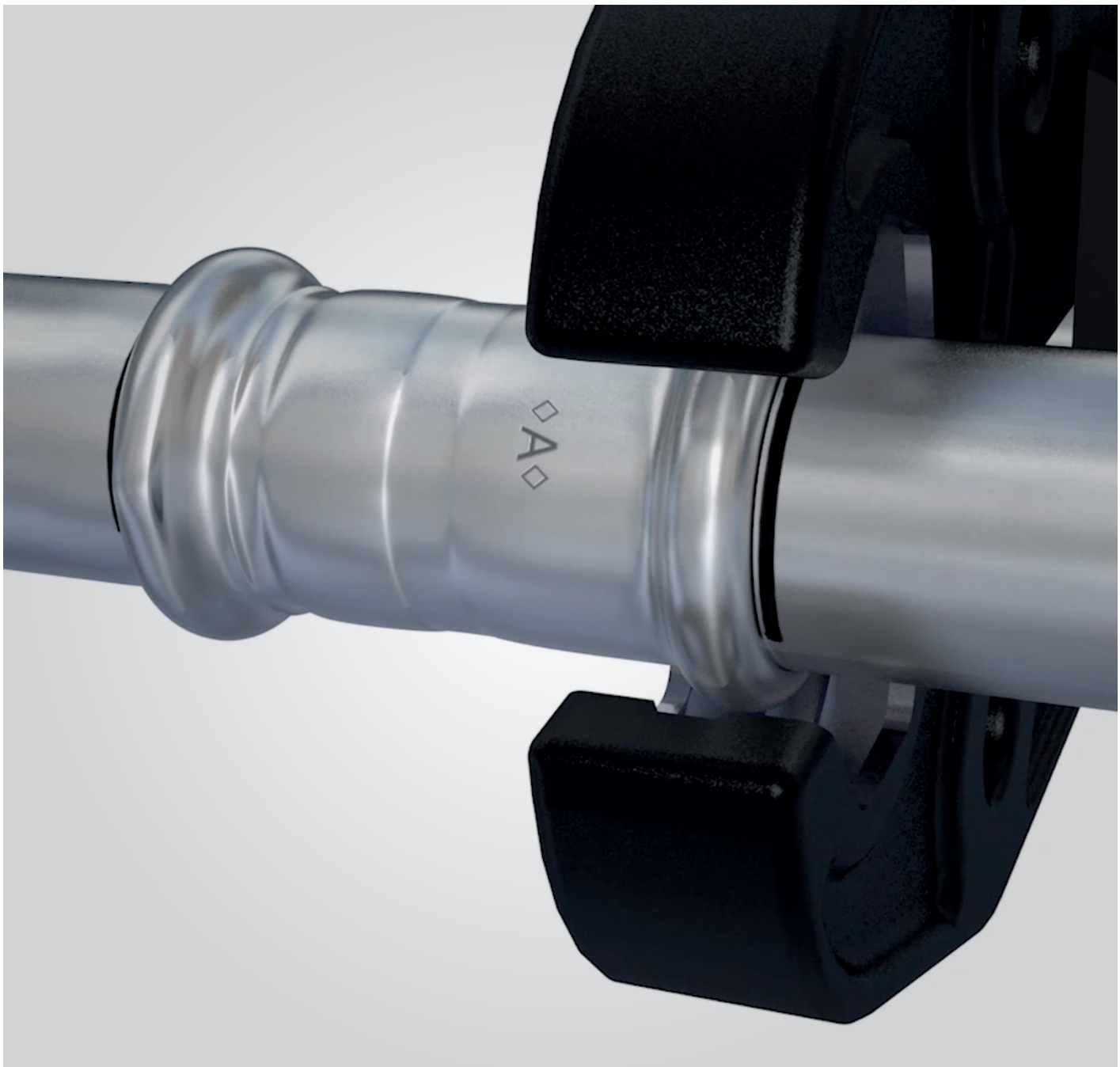

10. Fitting Installation Instructions

Leave the fittings in the packaging prior to final installation to protect them from contamination and to preserve the lubrication of the O-rings. Please note the space required for pressing tools (see section 9).

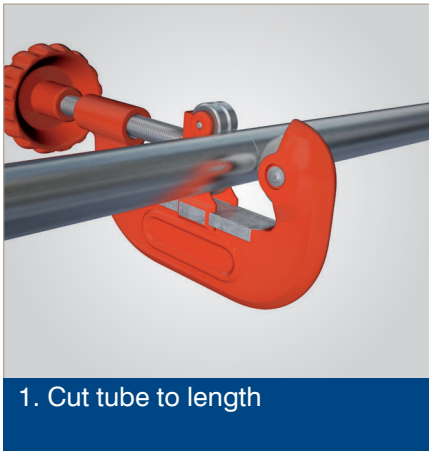

1. Cut tube to length

- Use a rotary tube cutter.
- Ensure that the tube is cut square.
- Check the tube has maintained its shape and is damage free.

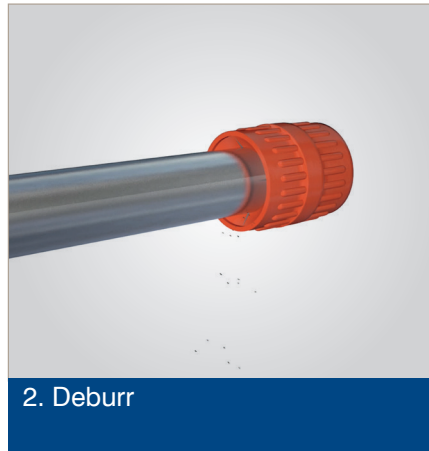

2. Deburr

- Deburr the tube both internally and externally.
- Where possible angle the tube downwards to prevent filings entering the tube.
- Make sure the internal and external surfaces of the tube ends are smooth and free from burrs and sharp edges.

Caution: Please ensure that the tube surface is free from any deep score or scratches.

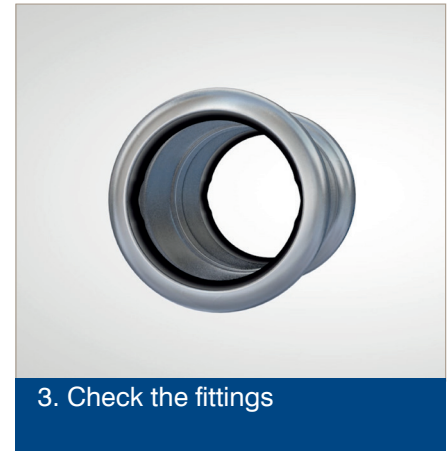

3. Check the fittings

- Check the fittings is the correct size for the tube.
- Check the O-rings are present and correctly seated.
- It is good practice to add a small amount of Conex Bänninger press fitting lubricant to the O-rings to aid tube insertion.

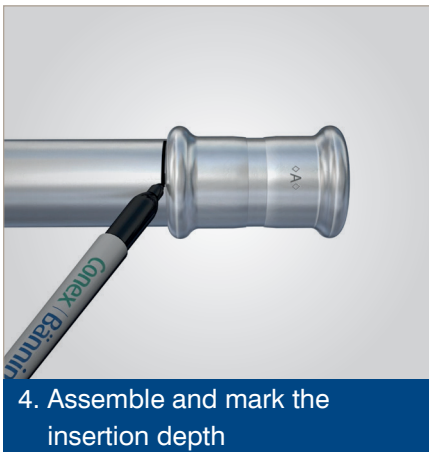

4. Assemble and mark the insertion depth

- The tube must be fully inserted into the fitting until it reaches the tube stop.
- To reduce the risk of dislodging the O-ring, rotate the tube (if possible) while slipping it into the fittings.
- Mark the insertion depth on the tube.
- Prior to pressing ensure the tube has not moved out from the fitting socket.



5. Complete the joint with the press tool

- Ensure pipework is correctly aligned prior to pressing.
- Ensure the correct size jaw is inserted into the tool.
- The jaws must be placed squarely on the fitting, locating the groove on the bead.
- The bead on the fitting should fit centrally in the groove of the jaw.
- Depress and hold the start button on the press tool to complete the pressing cycle.
- Pressing is complete when the jaws are fully closed.

Caution: The <A> Press Inox joint is complete after one full cycle of the tool. Do not crimp any <A> Press Inox fitting more than once.



6. Completed joint

- Mark the completed joint after pressing.
- This enables joints to be inspected easily before testing.

11. The Range

<p>PS24001 90° Street Elbow</p> 	<p>PS24002 90° Elbow</p> 	<p>PS24002G CxFi 90° Swivel Connector</p> 	<p>PS24040 45° Obtuse Street Elbow</p> 	<p>PS24041 45° Obtuse Elbow</p> 
<p>PS24085 Full Crossover Coupler</p> 	<p>PS24090G CxFi 90° Elbow ISO - 7</p> 	<p>PS24092G CxMi 90° Elbow ISO - 7</p> 	<p>PS24292 Plug End</p> 	<p>PS24130 Equal Tee</p> 
<p>PS24130 Reduced Branch Tee</p> 	<p>PS24130G CxCXFi Branch Tee ISO - 7</p> 	<p>PSDN133G CxCxMi Branch Tee ISO - 7</p> 	<p>PSDN230B Flange Adaptor PN16</p> 	<p>PSDN243 Fitting Reducer</p> 
<p>PS24355 CxFi Con Flat Seal Face</p> 	<p>PS24243G CxMi Coupler ISO - 7</p> 	<p>PS24270 Coupler</p> 	<p>PS24270G CxFi Coupler ISO - 7</p> 	<p>PS24301 Cap End</p> 
<p>PS24275 Slip Coupler</p> 	<p>PS24340G 3-Pcs Female Thread Union</p> 	<p>PS24341G 3-Pcs Male Thread Union</p> 	<p>PS24471G Wallplate Elbow ISO - 7</p> 	<p><A> Press Inox tube</p> 
<p>MPABPSOIL100ML Fitting Lubricant for O-ring</p> 				

*PS24 refers to material grade 304

PS24001 90° Street Elbow

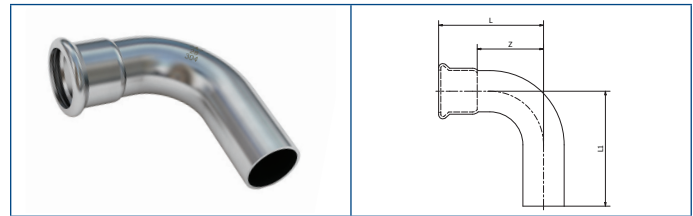

Code 304	Fitting size	L	L1	Z
PS24001 0150000	15	45	52	25
PS24001 0180000	18	50	57	30
PS24001 0220000	22	57	70	36
PS24001 0280000	28	68.5	76	45.5
PS24001 0350000	35	73.5	90	47.5
PS24001 0420000	42	85	100	55
PS24001 0540000	54	104	121	69
PS24001 0760000	76.1	177	166	124
PS24001 0890000	88.9	205	194	147
PS24001 1080000	108.0	247	240	175

PS24002 90° Elbow

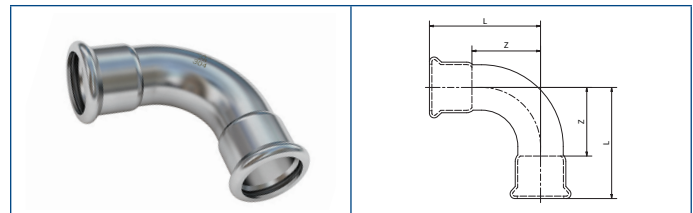

Code 304	Fitting size	L	Z
PS24002 0150000	15	45	25
PS24002 0180000	18	50	30
PS24002 0220000	22	57	36
PS24002 0280000	28	68.5	45.5
PS24002 0350000	35	73.5	47.5
PS24002 0420000	42	85	55
PS24002 0540000	54	104	69
PS24002 0760000	76.1	177	124
PS24002 0890000	88.9	205	147
PS24002 1080000	108.0	247	175

*All above measurements are in mm unless stated differently.

<A> Press Inox

PS24002G CxFi 90° Swivel Connector

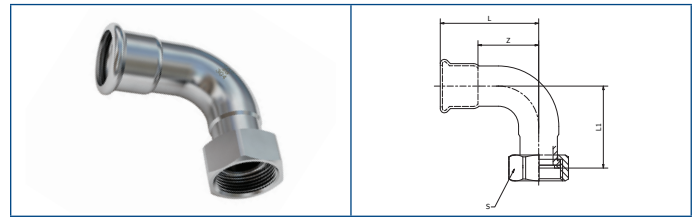

Code 304	Fitting size	L	L1	Z	S
PS24002G0150400	15 x 1/2"	45	38	25	24
PS24002G0180400	18 x 1/2"	50	43	30	24
PS24002G0220600	22 x 3/4"	57	47	36	30
PS24002G0280800	28 x 1"	68	58.5	45	37
PS24002G0351000	35 x 1 1/4"	73.5	65	47.5	46
PS24002G0421200	42 x 1 1/2"	85.5	83	55.5	52.5
PS24002G0541600	54 x 2"	116	106	81	64

PS24040 45° Obtuse Street Elbow

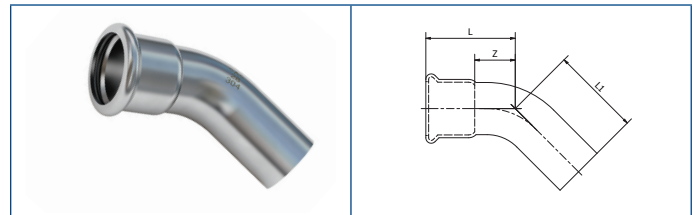

Code 304	Fitting size	L	L1	Z
PS24040 0150000	15	39	48	19
PS24040 0180000	18	39	48	19
PS24040 0220000	22	45	56	24
PS24040 0280000	28	52	60	29
PS24040 0350000	35	58	68	32
PS24040 0420000	42	70	78	40
PS24040 0540000	54	83	92	48
PS24040 0760000	76.1	113.5	111	60.5
PS24040 0890000	88.9	129	130	71
PS24040 1080000	108.0	156	157	84

PS24041 45° Obtuse Elbow

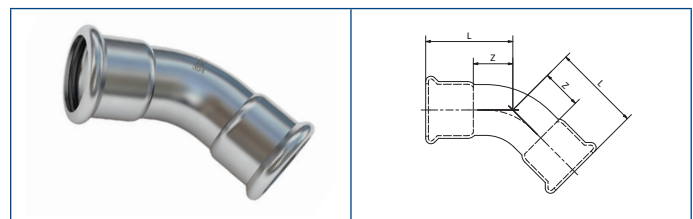

Code 304	Fitting size	L	Z
PS24041 0150000	15	36	16
PS24041 0180000	18	36	16
PS24041 0220000	22	42	21
PS24041 0280000	28	52	29
PS24041 0350000	35	58	32
PS24041 0420000	42	70	40
PS24041 0540000	54	75	40
PS24041 0760000	76.1	113.5	60.5
PS24041 0890000	88.9	129	71
PS24041 1080000	108.0	156	84

PS24085 Full Crossover Coupler

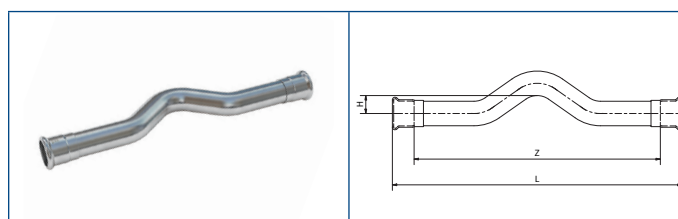

Code 304	Fitting size	L	Z	H
PS24085 0150000	15	167	127	12.5
PS24085 0180000	18	186	146	14
PS24085 0220000	22	203	161	16
PS24085 0280000	28	227.5	181.5	20.5

PS24090G CxFi 90° Elbow ISO - 7

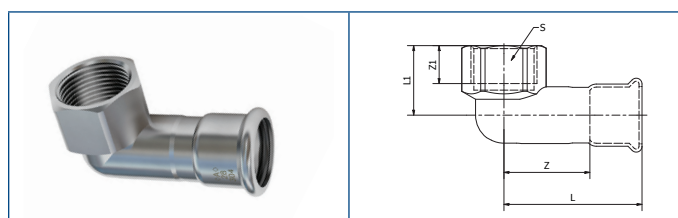

Code 304	Fitting size	L	L1	Z	Z1	S
PS24090G0150400	15 x 1/2"	53.5	26.5	33.5	15.5	26
PS24090G0180400	18 x 1/2"	53.7	25.7	33.7	15.5	26
PS24090G0220400	22 x 1/2"	53.7	25.7	32.7	15.5	26
PS24090G0220600	22 x 3/4"	61	31	40	16.5	32
PS24090G0280800	28 x 1"	69.5	35	46.5	20	38
PS24090G0351000	35 x 1 1/4"	77.5	40	51.5	21.5	48

PS24092G C x Mi 90° Elbow ISO - 7

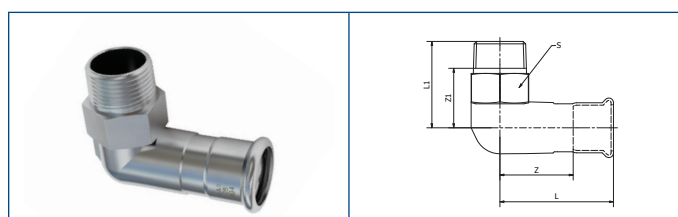

Code 304	Fitting size	L	L1	Z	Z1	S
PS24092G0150400	15 x 1/2"	59	37	39	21	24.5
PS24092G0180400	18 x 1/2"	61	37	41	21	24.5
PS24092G0220600	22 x 3/4"	62.5	46	41.5	29.5	28
PS24092G0280800	28 x 1"	71	54	48	35	34
PS24092G0351000	35 x 1 1/4"	78	55	52	33	44
PS24092G0421200	42 x 1 1/2"	84	60	54	35	50
PS24092G0541600	54 x 2"	97.5	65	62.5	38	62

<A> Press Inox

PS24292 Plug End

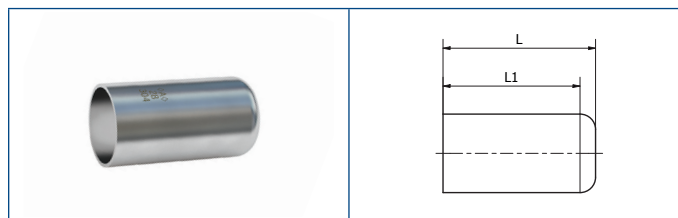

Code 304	Fitting size	L	L1
PS24292 0150000	15	47	42
PS24292 0220000	22	53	47.5
PS24292 0280000	28	54	49
PS24292 0350000	35	59	54
PS24292 0420000	42	59	54
PS24292 0540000	54	65	60

PS24130 Equal Tee

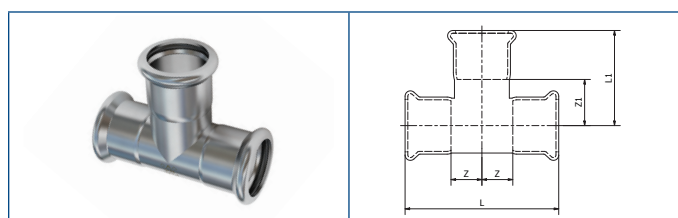

Code 304	Fitting size	L	L1	Z	Z1
PS24130 0151515	15	68	39	14	9.5
PS24130 0181818	18	68	42	14	10.5
PS24130 0222222	22	74	45	16	13.5
PS24130 0282828	28	84	52	19	17
PS24130 0353535	35	103	57	25	19.5
PS24130 0424242	42	116	62	28	23
PS24130 0545454	54	140	77	35	29.5
PS24130 0767676	76.1	224	108.5	64	55.5
PS24130 0898989	88.9	252	125.5	68	67.5
PS24T 108108108	108.0	304	151	80	79

PS24130** Reduced Branch Tee

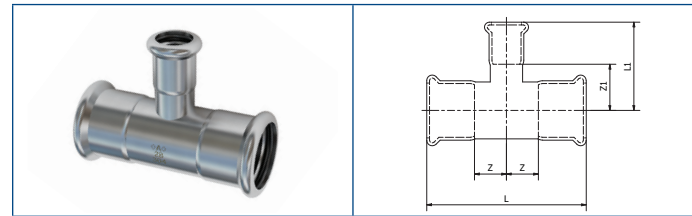

Code 304	Fitting size	L	L1	Z	Z1
PS24130 0181518	18 x 15 x 18	68	41.5	14	21.5
PS24130 0221522	22 x 15 x 22	74	43	16	23
PS24130 0221822	22 x 18 x 22	74	45	16	25
PS24130 0281528	28 x 15 x 28	84	46.5	19	26.5
PS24130 0281828	28 x 18 x 28	84	48.5	19	28.5
PS24130 0282228	28 x 22 x 28	84	48.5	19	27.5
PS24130 0351535	35 x 15 x 35	102.5	49	25	29
PS24130 0351835	35 x 18 x 35	102.5	51	25	31
PS24130 0352235	35 x 22 x 35	102.5	51	25	30
PS24130 0352835	35 x 28 x 35	102.5	54.5	25	31.5
PS24130 0421542	42 x 15 x 42	116	52.5	28	32.5
PS24130 0421842	42 x 18 x 42	116	54.5	28	34.5
PS24130 0422242	42 x 22 x 42	116	54.5	28	33.5
PS24130 0422842	42 x 28 x 42	116	58	28	35
PS24130 0423542	42 x 35 x 42	116	60.5	28	34.5
PS24130 0541554	54 x 15 x 54	140	59	35	39
PS24130 0541854	54 x 18 x 54	140	61.5	35	41.5
PS24130 0542254	54 x 22 x 54	140	61	35	40
PS24130 0542854	54 x 28 x 54	140	64.5	35	41.5
PS24130 0543554	54 x 35 x 54	140	67	35	41
PS24130 0544254	54 x 42 x 54	140	68.5	35	38.5
PS24130 0762276	76.1 x 22 x 76.1	224	72.5	64	52
PS24130 0762876	76.1 x 28 x 76.1	224	76	64	53.5
PS24130 0763576	76.1 x 35 x 76.1	224	78.5	64	52.5
PS24130 0764276	76.1 x 42 x 76.1	224	80	64	50
PS24130 0765476	76.1 x 54 x 76.1	224	88.5	64	54
PS24130 0892289	88.9 x 22 x 88.9	252	78	68	57
PS24130 0892889	88.9 x 28 x 88.9	252	82.5	68	60
PS24130 0893589	88.9 x 35 x 88.9	252	84	68	58
PS24130 0894289	88.9 x 42 x 88.9	252	86.5	68	56.5
PS24130 0895489	88.9 x 54 x 88.9	252	95	68	60.5
PS24130 0897689	88.9 x 76 x 88.9	252	114	68	61
PS24T 108022108	108 x 22 x 108	304	87	80	66
PS24T 108028108	108 x 28 x 108	304	93	80	70
PS24T 108035108	108 x 35 x 108	304	85	80	70
PS24T 108042108	108 x 42 x 108	304	103	80	73
PS24T 108054108	108 x 54 x 108	304	105.5	80	71
PS24T 108076108	108 x 76 x 108	304	124.5	80	71.5
PS24T 108089108	108 x 88.9 x 108	304	134	80	76

** The above description reads end, branch, end.

*All above measurements are in mm unless stated differently.

<A> Press Inox

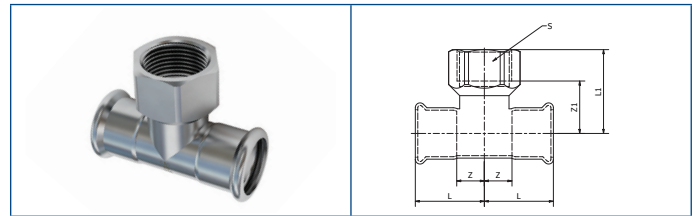

PS24130G** C x C x Fi Branch Tee ISO - 7

Code 304	Fitting size	L	L1	Z	S
PS24130G0150415	15 x 1/2" x 15	34	39.5	14	26
PS24130G0180418	18 x 1/2" x 18	34	41	14	26
PS24130G0180618	18 x 3/4" x 18	34	42	14	31
PS24130G0220422	22 x 1/2" x 22	37	43	16	26
PS24130G0220622	22 x 3/4" x 22	37	44	16	31
PS24130G0280428	28 x 1/2" x 28	42	46	19	26
PS24130G0280628	28 x 3/4" x 28	42	47	19	31
PS24130G0280828	28 x 1" x 28	42	51	19	39
PS24130G0350435	35 x 1/2" x 35	51	49	25	26
PS24130G0350635	35 x 3/4" x 35	51	50	25	31
PS24130G0350835	35 x 1" x 35	51	55.5	25	39
PS24130G0351035	35 x 1-1/4" x 35	51	55.5	25	48
PS24130G0420442	42 x 1/2" x 42	58	52	28	26
PS24130G0420642	42 x 3/4" x 42	58	53	28	31
PS24130G0420842	42 x 1" x 42	58	57	28	39
PS24130G0421242	42 x 1-1/2" x 42	58	61	28	55
PS24130G0540454	54 x 1/2" x 54	70	58	35	26
PS24130G0540654	54 x 3/4" x 54	70	59	35	31
PS24130G0540854	54 x 1" x 54	70	63	35	39
PS24130G0541654	54 x 2" x 54	70	73	35	67
PS24130G0760676	76 x 3/4" x 76	112	71.5	64	31
PS24130G0761676	76 x 2" x 76	112	85	59	67
PS24130G0890689	88,9 x 3/4" x 88,9	126	77.5	68	31
PS24130G0891689	88.9 x 2" x 88.9	126	90.5	68	67
PS24TG108006108	108 x 3/4" x 108	152	91	80	31
PS24TG108016108	108 x 2" x 108	152	100	80	67

20

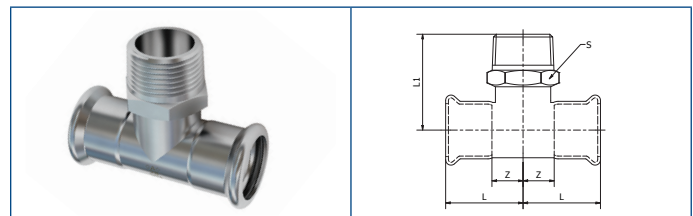

PS24133G** CxCxMi Branch Tee ISO - 7

Code 304	Fitting size	L	L1	Z	S
PS24133G0150315	15 x 3/8" x 15	34	34.5	14	19
PS24133G0150415	15 x 1/2" x 15	34	40	14	24
PS24133G0180418	18 x 1/2" x 18	34	42	14	24.5
PS24133G0180618	18 x 3/4" x 18	34	44	14	28
PS24133G0220622	22 x 3/4" x 22	37	48	16	28
PS24133G0280828	28 x 1" x 28	42	52	19	34
PS24133G0351035	35 x 1 1/4" x 35	51.2	60	25	44

** The above descriptions reads end, branch, end.

*All above measurements are in mm unless stated differently.

PS24230B Flange Adaptor PN16

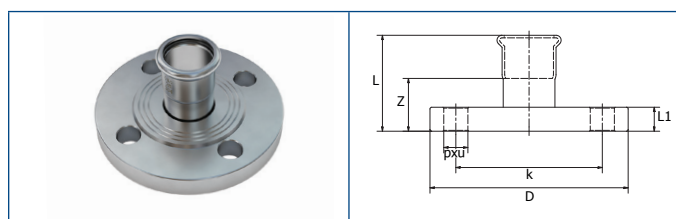

Code 304	Fitting size	L	L1	Z	D	k	d	n
PS24230B0150000	15	43	14	23	95	65	14	4
PS24230B0180000	18	43	14	23	95	65	14	4
PS24230B0220000	22	48	16	27	105	75	14	4
PS24230B0280000	28	56	16	33	115	85	14	4
PS24230B0350000	35	60.5	18	34.5	140	100	18	4
PS24230B0420000	42	73	18	43	140	100	18	4
PS24230B0540000	54	89	20	54	165	125	18	4
PS24230B0760000	76.1	109	20	56	185	145	18	8
PS24230B0890000	88.9	123	20	65	200	160	18	8
PS24230B1080000	108	150	22	78	220	180	18	8

PS24355 CxFi Con Flat Seal Face

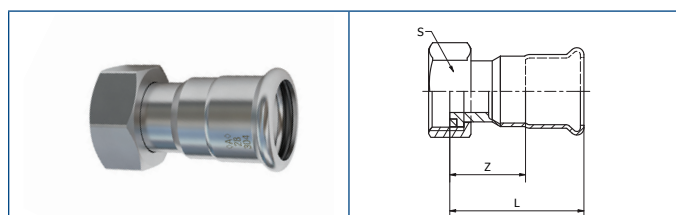

Code 304	Fitting size	L	Z	S
PS24355 0150400	15 x 1/2"	52.5	32.5	24
PS24355 0150600	15 x 3/4"	49.5	29.5	30
PS24355 0180400	18 x 1/2"	50.5	30.5	24
PS24355 0180600	18 x 3/4"	52.5	32.5	24
PS24355 0220600	22 x 3/4"	54.5	34.5	24
PS24355 0220800	22 x 1"	54.5	34.5	24
PS24355 0280800	28 x 1"	52.5	32.5	30
PS24355 0281000	28 x 1-1/4"	60.5	38	46
PS24355 0351000	35 x 1-1/4"	53.5	32.5	30
PS24355 0351200	35 x 1-1/2"	70.5	44.5	52.5
PS24355 0421200	42 x 1-1/2"	60	39	36
PS24355 0421600	42 x 2"	83.5	53.5	65
PS24355 0541600	54 x 2"	83	48	64

*All above measurements are in mm unless stated differently.

<A> Press Inox

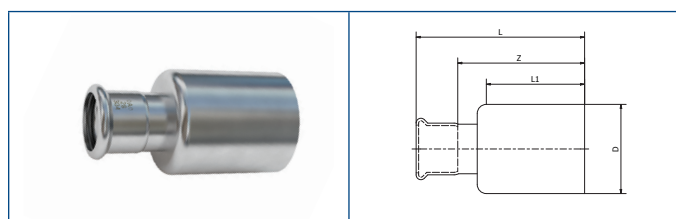

PS24243 Fitting Reducer

Code 304	Fitting size	D	L	L1	Z
PS24243 0181500	18 x 15	18	66	35.5	46
PS24243 0221500	22 x 15	22	67	32	45
PS24243 0221800	22 x 18	22	66	33	46
PS24243 0281500	28 x 15	28	92	45	68
PS24243 0281800	28 x 18	28	88.5	49	68.5
PS24243 0282200	28 x 22	28	73	40	52
PS24243 0351500	35 x 15	35	90	53	70
PS24243 0351800	35 x 18	35	92.5	53	72.5
PS24243 0352200	35 x 22	35	95	53	74
PS24243 0352800	35 x 28	35	85	58	75
PS24243 0421500	42 x 15	42	92	53	72
PS24243 0421800	42 x 18	42	93.5	45	73.5
PS24243 0422200	42 x 22	42	94	54	73
PS24243 0422800	42 x 28	42	96	52	73
PS24243 0423500	42 x 35	42	93	45	67
PS24243 0541500	54 x 15	54	99	60	79
PS24243 0541800	54 x 18	54	99.5	50	79.5
PS24243 0542200	54 x 22	54	99	60	78
PS24243 0542800	54 x 28	54	102	60	79
PS24243 0543500	54 x 35	54	104	59	78
PS24243 0544200	54 x 42	54	102	50	72
PS24243 0762200	76 x 22	76.1	138.5	70	117.5
PS24243 0762800	76 x 28	76.1	140	70	117
PS24243 0763500	76 x 35	76.1	142	70	116
PS24243 0764200	76.1 x 42	76.1	140	70	110
PS24243 0765400	76.1 x 54	76.1	145	70	110.5
PS24243 0894200	88.9 x 42	89.9	154	80	124
PS24243 0895400	88.9 x 54	88.9	156	80	121.5
PS24243 0897600	88.9 x 76.1	88.9	176	80	123
PS24243 1085400	108 x 54	108	180	95	145.5
PS24243 1087600	108 x 76	108	192	95	139
PS24243 1088900	108 x 88.9	108	210	95	152

PS24243G CxMi Coupler ISO - 7

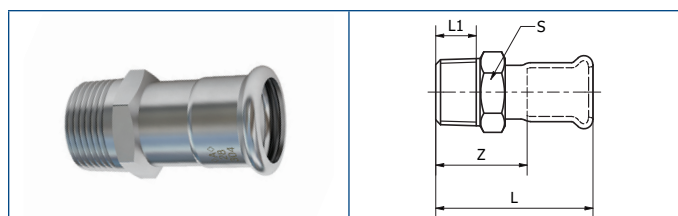

Code 304	Fitting size	L	min L1	Z	S
PS24243G0150300	15 x 3/8"	54	10.5	34	19
PS24243G0150400	15 x 1/2"	59.5	15	39.5	24
PS24243G0150600	15 x 3/4"	65.5	15.5	45.5	28
PS24243G0180400	18 x 1/2"	61.5	15	41.5	24
PS24243G0180600	18 x 3/4"	65.5	15.5	45.5	28
PS24243G0220400	22 x 1/2"	62.5	15	44.5	24
PS24243G0220600	22 x 3/4"	65.5	15.5	44.5	28
PS24243G0220800	22 x 1"	71	18	50	34
PS24243G0280600	28 x 3/4"	85	15.5	62	28
PS24243G0280800	28 x 1"	71	18	48	34
PS24243G0281000	28 x 1 1/4"	81	21	58	44
PS24243G0350800	35 x 1"	71.5	18	45.5	35
PS24243G0351000	35 x 1 1/4"	78.5	21	52.5	44
PS24243G0351200	35 x 1 1/2"	91	23.5	65	50
PS24243G0421000	42 x 1 1/4"	96	21	66	44
PS24243G0421200	42 x 1 1/2"	81	23.5	51	50
PS24243G0541200	54 x 1 1/2"	105.5	23.5	69.5	50
PS24243G0541600	54 x 2"	96.5	25.8	61.5	62
PS24243G0762000	76,1 x 2 1/2"	127.5	26.7	74.5	85
PS24243G0892400	88,9 x 3"	144.5	29.8	86.5	95
PS24243G1083200	108 x 4"	170	39.3	98	125

23

PS24270 Coupler



Code 304	Fitting size	L	Z
PS24270 0150000	15	48	8
PS24270 0180000	18	48	8
PS24270 0220000	22	50	8
PS24270 0280000	28	56	10
PS24270 0350000	35	65	13
PS24270 0420000	42	74	14
PS24270 0540000	54	86	16
PS24270 0760000	76.1	141	35
PS24270 0890000	88.9	162	42
PS24270 1080000	108.0	194	44

*All above measurements are in mm unless stated differently.

<A> Press Inox

PS24270G CxFi Coupler ISO -7

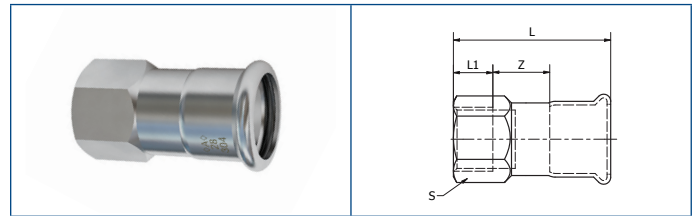

Code 304	Fitting size	L	L1	Z	S
PS24270G0150300	15 x 3/8"	54	13.5	20	19
PS24270G0150400	15 x 1/2"	58.5	15	22.5	26
PS24270G0150600	15 x 3/4"	61.5	16.3	24.5	31
PS24270G0180400	18 x 1/2"	60.5	15	24.5	26
PS24270G0180600	18 x 3/4"	61.5	16.3	24.5	31
PS24270G0220400	22 x 1/2"	60.5	15	23.5	26
PS24270G0220600	22 x 3/4"	62	16.3	24	31
PS24270G0220800	22 x 1"	69	19.1	28	39
PS24270G0280400	28 x 1/2"	80	15	42.5	26
PS24270G0280600	28 x 3/4"	65	16.3	25	31
PS24270G0280800	28 x 1"	69	19.1	26	39
PS24270G0281000	28 x 1 1/4"	75.5	21.4	30.5	48
PS24270G0350800	35 x 1"	87.5	19.1	41.5	39
PS24270G0351000	35 x 1 1/4"	73.5	21.4	24.5	48
PS24270G0351200	35 x 1 1/2"	86	21.4	38	55
PS24270G0421000	42 x 1 1/4"	92	21.4	39	48
PS24270G0421200	42 x 1 1/2"	77	21.4	24	55
PS24270G0541200	54 x 1 1/2"	102.5	21.4	44	55
PS24270G0541600	54 x 2"	91.5	25.7	29	67
PS24270G0762000	76 x 2 1/2"	115.5	26.6	35.5	84
PS24270G0892400	88.9 x 3"	133	28.2	47	96

24

PS24275 Slip Coupler

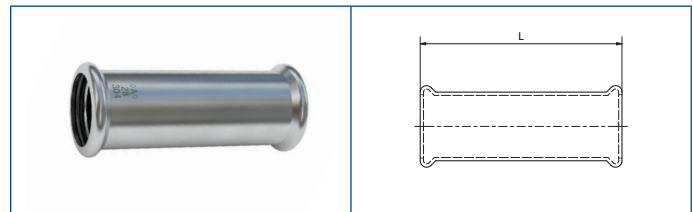

Code 304	Fitting size	L
PS24275 0150000	15	74
PS24275 0180000	18	78
PS24275 0220000	22	83
PS24275 0280000	28	92
PS24275 0350000	35	101
PS24275 0420000	42	118
PS24275 0540000	54	142
PS24275 0760000	76.1	224
PS24275 0890000	88.9	252
PS24275 1080000	108	304

*All above measurements are in mm unless stated differently.

PS24301 Cap End

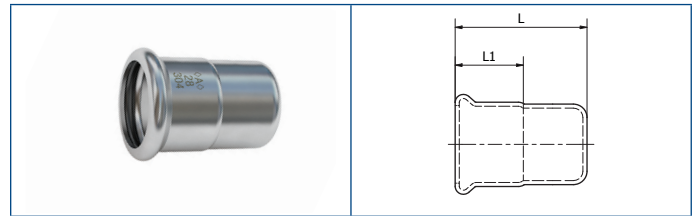

Code 304	Fitting size	L	L1
PS24301 0150000	15	41	20
PS24301 0180000	18	43	20
PS24301 0220000	22	44	21
PS24301 0280000	28	47.5	23
PS24301 0350000	35	51	26
PS24301 0420000	42	52.5	30
PS24301 0540000	54	62	35
PS24301 0760000	76.1	101	53
PS24301 0890000	88.9	112	58
PS24301 1080000	108	134	72

PS24340G 3-pcs female thread union

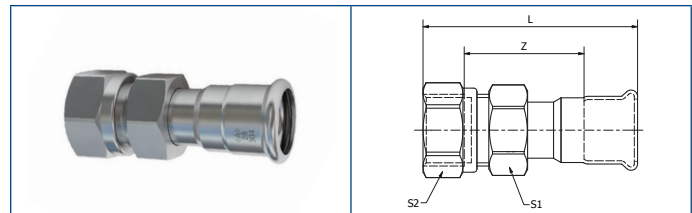

Code 304	Fitting size	L	Z	S1	S2
PS24340G0150400	15 x 1/2"	74.5	32.5	24	22
PS24340G0150600	15 x 3/4"	78.5	34.5	30	27
PS24340G0180400	18 x 1/2"	76.5	34.5	24	22
PS24340G0180600	18 x 3/4"	77.5	32.5	30	27
PS24340G0220600	22 x 3/4"	77.5	32.5	30	27
PS24340G0220800	22 x 1"	84.5	35.5	36	34
PS24340G0280800	28 x 1"	88	37	36	34
PS24340G0281000	28 x 1 1/4"	91	38	46	43
PS24340G0351000	35 x 1 1/4"	93.5	37.5	46	43
PS24340G0421200	42 x 1 1/2"	106	44	52.5	50
PS24340G0541600	54 x 2"	120	48	65	60

*All above measurements are in mm unless stated differently.

<A> Press Inox

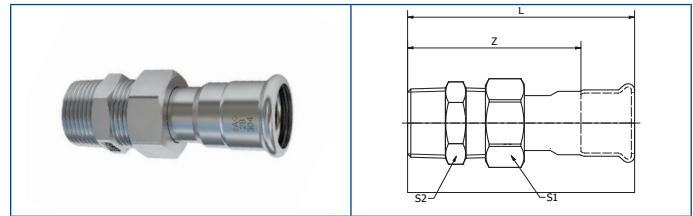

PS24341G 3-pcs male thread union

Code 304	Fitting size	L	Z	S1	S2
PS24341G0150400	15 x 1/2"	91.5	71.5	24	21.5
PS24341G0150600	15 x 3/4"	94.5	74.5	30	27
PS24341G0180400	18 x 1/2"	93.5	73.5	24	21.5
PS24341G0180600	18 x 3/4"	91.5	71.5	30	27
PS24341G0220400	22 x 1/2"	87	67	30	28
PS24341G0220600	22 x 3/4"	94.5	73.5	30	27
PS24341G0220800	22 x 1"	101	80	36	34
PS24341G0280800	28 x 1"	104.5	81.5	36	34
PS24341G0281000	28 x 1 1/4"	109	86	46	43
PS24341G0351000	35 x 1 1/4"	111.5	85.5	46	43
PS24341G0421200	42 x 1 1/2"	125	95	52.5	50
PS24341G0541600	54 x 2"	141	106	64	62

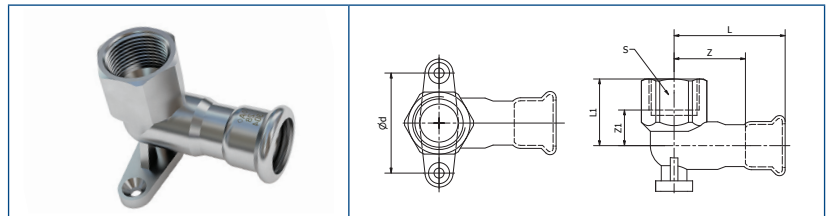

PS24471G Wallplate Elbow ISO -7

Code 304	Fitting size	L	L1	Z	Z1	ød	S
PS24471G0150400	15 x 1/2"	48.5	27	28.5	12	45	26
PS24471G0180400	18 x 1/2"	50.5	27	30.5	12	45	26
PS24471G0220600	22 x 3/4"	58	35	37	18	50	31

<A> Press Inox



Fitting Lubricant for O-ring

Code	Size
MPABPSOIL100ML	100 ml



<A> Press Inox Tube

Code	Grade	Length (M)	Marking
PSTUBE-304-15	304	6	<A>
PSTUBE-304-15T			
PSTUBE-304-18			
PSTUBE-304-18T			
PSTUBE-304-22			
PSTUBE-304-22T			
PSTUBE-304-28			
PSTUBE-304-28T			
PSTUBE-304-35			
PSTUBE-304-35T			
PSTUBE-304-42			
PSTUBE-304-42T			
PSTUBE-304-54			
PSTUBE-304-54T			
PSTUBE-304-76			
PSTUBE-304-76T			
PSTUBE-304-89T			
PSTUBE-304-108T			

*All above measurements are in mm unless stated differently.

12. Product Guarantee

When professionally installed, used and maintained in accordance with the installation and maintenance instructions detailed in the <A> Press Inox technical brochure available on the Conex Bänninger website www.conexbanninger.com.

304

Conex Universal Ltd. guarantees that <A> Press Inox (304) supplied by Conex Universal Ltd. will be free of material defects resulting from errors in manufacture, for ten (10) years from the date of first purchase by an end user. This Guarantee is limited to the repair or replacement of defective product(s) (at the sole discretion of Conex Universal Ltd.). At the request of Conex Universal Ltd. the allegedly defective product(s) must be returned to the address below* and Conex Universal Ltd. reserves the right to inspect and test the alleged defects. This guarantee provided by Conex Universal Ltd. does not affect your statutory rights.

The Guarantee set out above is given by Conex Universal Ltd. and subject to the following conditions:

- A. Any alleged defects must be reported to Conex Universal Ltd. within one month of the first occurrence of any such alleged defect, clearly setting out the nature of the claim and the circumstances surrounding it.
- B. Conex Universal Ltd. shall be under no liability in respect of any defect in any product arising from:
- defective installation,
 - fair wear and tear,
 - wilful damage,
 - negligence of any party other than Conex Universal Ltd.,
 - abnormal working or environmental conditions,
 - failure to follow the instructions of Conex Universal Ltd.,
 - misuse (which includes any use of the product(s) concerned for a purpose or in a situation / environment or for an application other than that for which it was designed), or
 - alteration or repair of any product without the prior approval of Conex Universal Ltd.
- C. At the request of Conex Universal Ltd. the person claiming under this guarantee must deliver to Conex Universal Ltd. written evidence of the date of first purchase by an end user of the product(s) concerned.

*** The address for returns is:**

Customer Services at Conex Universal Limited.
Global House, 95 Vantage Point, The Pensnett Estate,
Kingswinford, West Midlands, DY6 7FT,
UNITED KINGDOM

International Contacts

United Kingdom Tel: +44 (0)121 557 2831 Email: salesuk@ibpgroup.com	Global House, 95 Vantage Point The Pensnett Estate, Kingswinford, West Midlands DY6 7FT UK	
Africa Tel: +351 918 805 900 Email: sales.africa@ibpgroup.com	Poligono Industrial Quintos Aeropuerto 14005 Spain	
China Tel: 0086 4001085686 Email: nbibp@ibpchina.com	Technical Service Center Floor 43, Building A, International Trade Center, Ningbo Chamber of Commerce No.558 of Taikangzhong Road, Yinzhou District, Ningbo, China 315100	
France Tel: +33 967 579 554 Email: sales.france@ibpgroup.com	45 Rue Boissiere, Paris, 75016 France	
Germany and Central Europe Tel: +49 (0) 6403 / 77 85 – 0 Email: customerservicede@ibpgroup.com	Theodor-Heuss-Strabe 18 35440 Linden, Germany	
International (Rest of world) Tel: +44 (0)121 521 2921 Email: international@ibpgroup.com	Global House, 95 Vantage Point The Pensnett Estate, Kingswinford, West Midlands DY6 7FT UK	
Italy Tel: +39 0521 299711 Email: tecnico.ibpbanneritalia@ibpgroup.com	Piazza Meccio Ruini 9A 43126 Parma Italy	
Middle East Tel: +971 (0) 4 434 0082 Email: gulf@ibpgroup.com	One JLT Tower, Level 5, Office 12 Jumeirah Lake Towers Dubai, UAE	
Poland and Eastern Europe Tel: +48 61 660 96 40 Mob: +48 603 421 244 Email: customerservicePO@ibpgroup.com	ul. Stanislaw Zwierzchowskiego 29 61-249 Poznan, Poland	ul. Za Motelem 2A Tarnowo Podgorne 62-080 Sady, Poland
Spain and Portugal Spain: Tel: +34 957 469 629 Email: Sales.spain@ibpgroup.com Portugal: Tel: +351 918 805 900 Email: salesportugal@ibpgroup.com	Poligono Industrial Quintos Aeropuerto 14005 Spain	
USA Tel: 904-217-4970 Email: salesUSA@ibpgroup.com	Suite 400, 24 Cathedral Place St Augustine, Florida 32084	

Note: The full range of Conex Bänninger products may not be available for sale in your country. Please contact customer services to discuss range availability.

›B‹ Press

›B‹ Press Gas

›B‹ Press Solar

›B‹ Press XL

›B‹ Press Carbon

›B‹ Press Inox

›B‹ Steel

›B‹ MaxiPro

›B‹ ACR

K65

‹A› Press Inox

›B‹ Push

›B‹ Sonic

›B‹ Oyster

›B‹ Flex

Triflow Solder Ring

Delcop End Feed

Delbraze

Medical Gas

Valves

Conex Compression

Series 3000

Series 4000

Series 5000

Series 8000

OEM Solutions

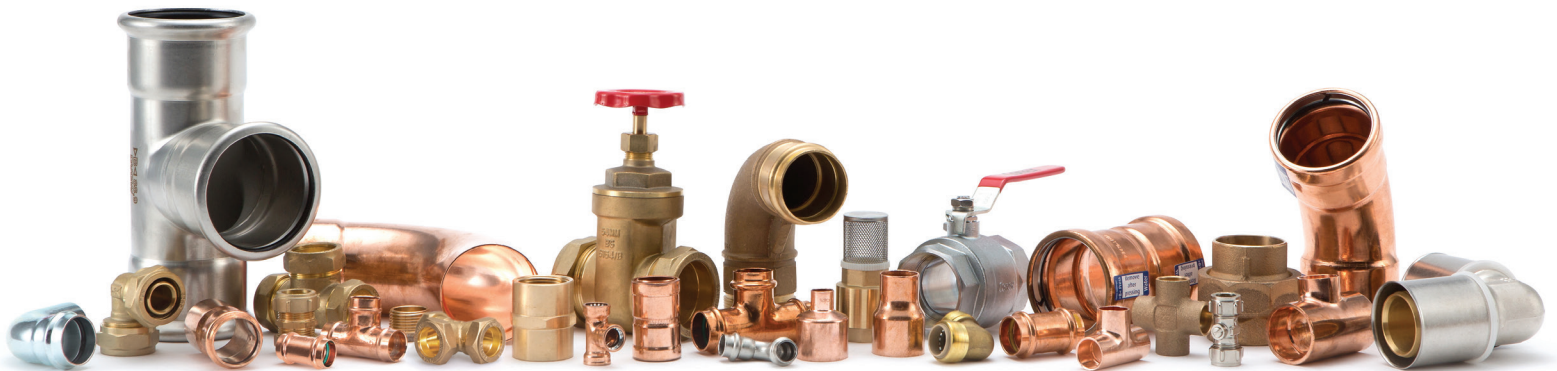

United Kingdom
Conex Universal Limited

Germany
IBP GmbH

Spain
IBP Atcosa SL

France
Conex Bänninger SRL

Italy
IBP Bänninger Italia srl

Poland Sales, Marketing and Logistics
IBP Instalittings Sp z.o.o.

USA
IBP Group LLC

China
IBP China

Tel: +44 (0)121 557 2831 | Fax: +44 (0)121 557 0185 | Email: salesuk@ibpgroup.com | Website: www.conexbanninger.com

The content of this publication is for general information only. It is the user's responsibility to determine suitability of any product, product data and specifications, for the purpose intended and reference should be made to our Technical Department if clarification is required – technical@ibpgroup.com. All products must be installed in accordance with our installation instructions. In the interests of technical development we reserve the right to change specification, design and materials without notice.

Conex Bänninger products are approved by numerous Standards Authorities and Certification Bodies. This is a representation of the full range from Conex Universal Ltd. Patents and trademarks are registered in numerous countries. Details on registered and pending patents protecting our products is available at public patent registers or can be requested from legal@ibpgroup.com. All documents, images and technical data are © of Conex Universal Limited, E&OA.

More information online at: www.conexbanninger.com